

## MODEL PAXT - 1/8 DIN THERMOCOUPLE AND RTD PANEL METER



UL Recognized Component,  
 File # E179259

- THERMOCOUPLE AND RTD INPUTS
- CONFORMS TO ITS-90 STANDARDS
- EASY STEP BY STEP INSTRUCTIONS
- OPTIONAL CUSTOM UNITS OVERLAY W/ BACKLIGHT
- CUSTOM SCALING FOR NON-STANDARD PROBES
- TIME-TEMPERATURE INTEGRATOR
- PROGRAMMABLE INPUT AND OUTPUT RESPONSE TIMES
- PROGRAMMABLE FUNCTION KEYS / USER INPUTS
- FOUR SETPOINT ALARM OUTPUTS (W/Plug-in card)
- COMMUNICATION AND BUS CAPABILITIES (W/Plug-in card)
- ANALOG OUTPUT SIGNAL (W/Plug-in card)
- PC SOFTWARE AVAILABLE FOR METER CONFIGURATION
- NEMA 4X/IP65 SEALED FRONT BEZEL
- 9 DIGIT TOTALIZER (INTEGRATOR) WITH BATCHING

### GENERAL DESCRIPTION

The PAXT (PAX Temperature Meter) offers many features and performance capabilities to suit a wide range of industrial applications. The meter employs advanced technology for stable, drift free readout, while incorporating features that provide flexibility now and in the future with plug-in option cards. The plug-in card options allow the opportunity to configure the meter for present applications, while providing easy upgrades for future needs.

The PAXT Temperature meter accepts inputs from a variety of thermocouple and RTD inputs, including 10 ohm copper and 120 ohm nickel, while conforming to the standards of ITS-90. The meter can be programmed to accept custom and non-standard thermocouple and RTD elements, via a 16-point custom scaling feature.

The meter provides a Max and Min reading memory with programmable capture time. The capture time is used to prevent detection of false max and min readings which may occur during start-up or unusual process events.

The signal totalizer (integrator) can be used to compute a time-temperature product. This can be used to provide a readout of temperature integration, useful in curing and sterilization applications.

The meter has four setpoint outputs, implemented on Plug-in cards. The Plug-in cards provide dual FORM-C relays (5 A), quad FORM-A relays (3 A) or either quad sinking or quad sourcing open collector logic outputs. The setpoint alarms can be configured in modes to suit a variety of control and alarm requirements.

Plug-in cards also facilitate bus communications. These include RS232, RS485 and MODBUS. Readout values and setpoint alarm values can be controlled through the bus. Additionally, the meter has features that allow a remote computer to directly control the outputs of the meter. With a communication card installed, it is possible to configure the meter using a Windows based program. The configuration data can be saved to a file for later recall.

A linear DC output signal is available as a Plug-in card. The card provides either 20 mA or 10 V signals. The output can be scaled independent of the input range. The features of the linear output cards are:

- Output tracks either input, totalizer, max or min readings
- Programmable output update times

Once the meter has been initially configured, the parameter list may be locked out from further modification in its entirety or only the setpoint values can be made accessible.

The meter has been specifically designed for harsh industrial environments. With NEMA 4X/IP65 sealed bezel and extensive testing of noise effects to CE requirements, the meter provides a tough yet reliable application solution.

### SAFETY SUMMARY

All safety related regulations, local codes and instructions that appear in this literature or on equipment must be observed to ensure personal safety and to prevent damage to either the instrument or equipment connected to it. If equipment is used in a manner not specified by the manufacturer, the protection provided by the equipment may be impaired.

Do not use this unit to directly command motors, valves, or other actuators not equipped with safeguards. To do so can be potentially harmful to persons or equipment in the event of a fault to the unit.



**CAUTION:** Read complete instructions prior to installation and operation of the unit.



**CAUTION:** Risk of electric shock.

### DIMENSIONS "In inches (mm)"

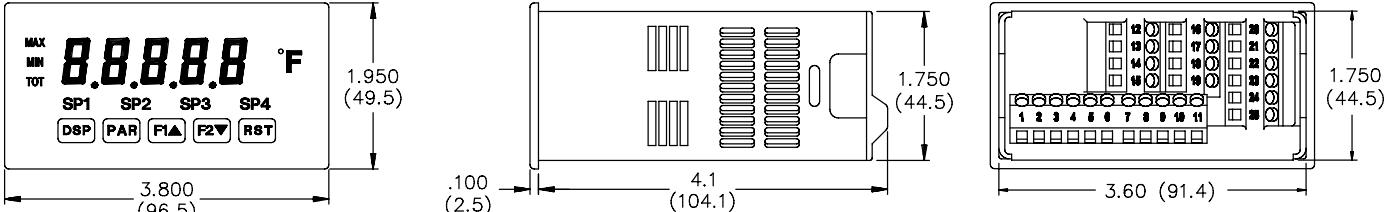

MAX MIN TOT 8.8.8.8.8 °F  
 SP1 SP2 SP3 SP4  
 DSP PAR F1A F2V RST

3.800 (96.5) 1.950 (49.5)

.100 (2.5) 4.1 (104.1) 1.750 (44.5)

3.60 (91.4) 1.750 (44.5)

Note: Recommended minimum clearance (behind the panel) for mounting clip installation is 2.1" (53.4) H x 5.0" (127) W.

## SPECIFICATIONS

1. **DISPLAY:** 5 digit, 0.56" (14.2 mm) red LED, (-19999 to 99999)

2. **POWER:**

AC Versions (PAXT0000):

AC Power: 85 to 250 VAC, 50/60 Hz, 15 VA

Isolation: 2300 Vrms for 1 min. to all inputs and outputs. (300 V working)

DC Versions (PAXT0010):

DC Power: 11 to 36 VDC, 11 W

(derate operating temperature to 40° C if operating <15 VDC and three plug-in cards are installed)

AC Power: 24 VAC, ± 10%, 50/60 Hz, 15 VA

Isolation: 500 Vrms for 1 min. to all inputs and outputs (50 V working).

3. **ANNUNCIATORS:**

MAX - maximum readout selected

MIN - minimum readout selected

TOT - totalizer readout selected, flashes when total overflows

SP1 - setpoint alarm 1 is active

SP2 - setpoint alarm 2 is active

SP3 - setpoint alarm 3 is active

SP4 - setpoint alarm 4 is active

Units Label - optional units label backlight

4. **KEYPAD:** 3 programmable function keys, 5 keys total

5. **A/D CONVERTER:** 16 bit resolution

6. **UPDATE RATES:**

A/D conversion rate: 20 readings/sec.

Step response: 200 msec. typ., 700 msec. max. to within 99% of final readout value (digital filter disabled)

Display update rate: 1 to 20 updates/sec.

Setpoint output on/off delay time: 0 to 3275 sec.

Analog output update rate: 0 to 10 sec

Max./Min. capture delay time: 0 to 3275 sec.

7. **DISPLAY MESSAGES:**

"OLOL" - Appears when measurement exceeds + sensor range.

"ULUL" - Appears when measurement exceeds - sensor range.

"OPEN" - Appears when open sensor is detected.

"SHrt" - Appears when shorted sensor is detected (*RTD only*)

"..." - Appears when display values exceed + display range.

"-..." - Appears when display values exceed - display range.

8. **READOUT:**

Resolution: Variable: 0.1, 0.2, 0.5, or 1, 2, or 5 degree

Scale: F or C

Offset Range: -19,999 to 99,999 display units

9. **THERMOCOUPLE INPUTS:**

Input Impedance: 20 MΩ

Lead Resistance Effect: 0.03μV/ohm

Max. Continuous Overvoltage: 30 V

Input Type	Range	Accuracy*	Accuracy*	Standard	Wire Color	
		(18 to 28°C)	(0 to 50°C)		ANSI	BS 1843
T	-200 to 400°C -270 to -200°C	1.2°C **	2.1°C	ITS-90	(+) blue (-) red	(+) white (-) blue
E	-200 to 871°C -270 to -200°C	1.0°C **	2.4°C	ITS-90	(+) purple (-) red	(+) brown (-) blue
J	-200 to 760°C	1.1°C	2.3°C	ITS-90	(+) white (-) red	(+) yellow (-) blue
K	-200 to 1372°C -270 to -200°C	1.3°C **	3.4°C	ITS-90	(+) yellow (-) red	(+) brown (-) blue
R	-50 to 1768°C	1.9°C	4.0°C	ITS-90	no standard	(+) white (-) blue
S	-50 to 1768°C	1.9°C	4.0°C	ITS-90	no standard	(+) white (-) blue
B	100 to 300°C 300 to 1820°C	3.9°C 2.8°C	5.7°C 4.4°C	ITS-90	no standard	no standard
N	-200 to 1300°C -270 to -200°C	1.3°C **	3.1°C	ITS-90	(+) orange (-) red	(+) orange (-) blue
C (W5/W26)	0 to 2315°C	1.9°C	6.1°C	ASTM E988-90***	no standard	no standard

\*After 20 min. warm-up. Accuracy is specified in two ways: Accuracy over an 18 to 28°C and 15 to 75 RH environment; and Accuracy over a 0 to 50°C and 0 to 85 RH (non condensing) environment. Accuracy specified over the 0 to 50°C operating range includes meter tempco and ice point tracking effects. The specification includes the A/D conversion errors, linearization conformity, and thermocouple ice point compensation. Total system accuracy is the sum of meter and probe errors. Accuracy may be improved by field calibrating the meter readout at the temperature of interest.

\*\* The accuracy over the interval -270 to -200°C is a function of temperature, ranging from 1°C at -200°C and degrading to 7°C at -270°C. Accuracy may be improved by field calibrating the meter readout at the temperature of interest.

\*\*\* These curves have been corrected to ITS-90.

10. **RTD INPUTS:**

Type: 3 or 4 wire, 2 wire can be compensated for lead wire resistance

Excitation current: 100 ohm range: 165 μA

10 ohm range: 2.6 mA

Lead resistance: 100 ohm range: 10 ohm/lead max.

10 ohm range: 3 ohms/lead max.

Max. continuous overload: 30 V

Input Type	Range	Accuracy*	Accuracy*	Standard ***
		(18 to 28°C)	(0 to 50°C)	
100 ohm Pt alpha = .00385	-200 to 850°C	0.4°C	1.6°C	IEC 751
100 ohm Pt alpha = .003919	-200 to 850°C	0.4°C	1.6°C	no official standard
120 ohm Nickel alpha = .00672	-80 to 260°C	0.2°C	0.5°C	no official standard
10 ohm Copper alpha = .00427	-100 to 260°C	0.4°C	0.9°C	no official standard

11. **CUSTOM RANGE:** Up to 16 data point pairs

Input range: -10 to 65 mV

0 to 400 ohms, high range

0 to 25 ohms, low range

Display range: -19999 to 99999

Input Type	Range	Accuracy*	Accuracy*
		(18 to 28°C)	(0 to 50°C)
Custom mV range	-10 to 65mV (1 μV res.)	0.02% of reading + 4μV	0.12% of reading + 5μV
Custom 100 ohm range	0 to 400 Ω (10 mΩ res.)	0.02% of reading + 0.04 Ω	0.12% of reading + 0.05 Ω
Custom 10 ohm range	0 to 25 Ω (1 mΩ res.)	0.04% of reading + 0.005 Ω	0.20% of reading + 0.007 Ω

12. **LOW FREQUENCY NOISE REJECTION:**

Normal Mode: > 60 dB @ 50 or 60 Hz ±1%, digital filter off

Common Mode: >100 dB, DC to 120 Hz

13. **USER INPUTS:** Three programmable user inputs

Max. Continuous Input: 30 VDC

Isolation To Sensor Input Common: Not isolated

Response Time : 50 msec. max.

Logic State: Jumper selectable for sink/source logic

INPUT STATE	SINKING INPUTS	SOURCING INPUTS
	22 KΩ pull-up to +5 V	22 KΩ pull-down
Active	V <sub>IN</sub> < 0.7 VDC	V <sub>IN</sub> > 2.5 VDC
Inactive	V <sub>IN</sub> > 2.5 VDC	V <sub>IN</sub> < 0.7 VDC

14. **TOTALIZER:**

Function:

Time Base: second, minute, hour, or day

Batch: Can accumulate (gate) input display from a user input

Time Accuracy: 0.01% typical

Decimal Point: 0 to 0.0000

Scale Factor: 0.001 to 65,000

Low Signal Cut-out: -19,999 to 99,999

Total: 9 digits, display alternates between high order and low order readouts

15. **CUSTOM LINEARIZATION:**

Data Point Pairs: Selectable from 2 to 16

Display Range: -19,999 to 99,999

Ice Point Compensation: user value (0.00 to 650.00 μV/°C)

Decimal Point: 0 to 0.0000

16. **SERIAL COMMUNICATIONS CARD:** Field installable plug-in card

**RS485 or RS232 Card:**

Isolation To Sensor & User Input Commons: 500 Vrms for 1 min.

Working Voltage: 50 V. Not Isolated from all other commons.

Data: 7/8 bits

Baud: 300 to 19,200

Parity: no, odd or even

Bus Address: selectable 0 to 99, Max. 32 meters per line (RS485)

Transmit Delay: Selectable for 2 to 50 msec or 50 to 100 msec (RS485)

**MODBUS Card:**

Type: RS485; RTU and ASCII MODBUS Modules  
 Isolation To Sensor & User Input Commons: 500 Vrms for 1 min.  
 Working Voltage: 50 V. Not Isolated from all other commons.  
 Baud Rates: 300, 600, 1200, 2400, 4800, 9600, 19200 and 38400.  
 Addresses: 1-247.  
 Format: 7/8 bits, odd, even, and no parity  
 Transmit Delay: Programmable

**17. ANALOG OUTPUT CARD:** Field installable plug-in card

Types: 0 to 20 mA, 4 to 20 mA or 0 to 10 VDC  
 Isolation To Sensor & User Input Commons: 500 Vrms for 1 min.  
 Working Voltage: 50 V. Not Isolated from all other commons.  
 Accuracy: 0.17% of FS (18 to 28°C); 0.4% of FS (0 to 50°C)  
 Resolution: 1/3500  
 Compliance: 10 VDC: 10 K $\Omega$  load min., 20 mA: 500  $\Omega$  load max.  
 Response Time: 200 msec. typ., 700 msec. max. to within 99% of final output value (digital filter disabled)

**18. SETPOINT OUTPUT CARD:** Four types of field installable plug-in cards**Dual Relay Card:**

Type: Two FORM-C relays  
 Isolation To Sensor & User Input Commons: 2000 Vrms for 1 min.  
 Working Voltage: 240 Vrms  
 Contact Rating:  
 One Relay Energized: 5 amps @ 120/240 VAC or 28 VDC (resistive load), 1/8 HP @ 120 VAC, inductive load  
 Total current with both relays energized not to exceed 5 amps  
 Life Expectancy: 100 K cycles min. at full load rating. External RC snubber extends relay life for operation with inductive loads  
 Response Time: 200 msec. typ., 700 msec. max. to within 99% of final output value (digital filter disabled)

**Quad Relay Card:**

Type: Four FORM-A relays  
 Isolation To Sensor & User Input Commons: 2300 Vrms for 1 min.  
 Working Voltage: 250 Vrms  
 Contact Rating:  
 One Relay Energized: 3 amps @ 250 VAC or 30 VDC (resistive load), 1/10 HP @ 120 VAC, inductive load  
 Total current with all four relays energized not to exceed 4 amps  
 Life Expectancy: 100K cycles min. at full load rating. External RC snubber extends relay life for operation with inductive loads  
 Response Time: 200 msec. typ., 700 msec. max. to within 99% of final output value (digital filter disabled)

**Quad Sinking Open Collector Card:**

Type: Four isolated sinking NPN transistors.  
 Isolation To Sensor & User Input Commons: 500 Vrms for 1 min.  
 Working Voltage: 50 V. Not Isolated from all other commons.  
 Rating: 100 mA max @  $V_{SAT} = 0.7$  V max.  $V_{MAX} = 30$  V  
 Response Time: 200 msec. typ., 700 msec. max. to within 99% of final output value (digital filter disabled)

**Quad Sourcing Open Collector Card:**

Type: Four isolated sourcing PNP transistors.  
 Isolation To Sensor & User Input Commons: 500 Vrms for 1 min.  
 Working Voltage: 50 V. Not Isolated from all other commons.

Rating: Internal supply: 24 VDC  $\pm$  10% , 30 mA max. total  
 External supply: 30 VDC max., 100 mA max. each output  
 Response Time: 200 msec. typ., 700 msec. max. to within 99% of final output value (digital filter disabled)

19. **MEMORY:** Nonvolatile E<sup>2</sup>Prom retains all programmable parameters and display values.

**20. ENVIRONMENTAL CONDITIONS:**

Operating Temperature Range: 0 to 50°C (0 to 45°C with all three plug-in cards installed)  
 Storage Temperature Range: -40 to 60°C  
 Operating and Storage Humidity: 0 to 85% max. non-condensing  
 Altitude: Up to 2000 meters

**21. CERTIFICATIONS AND COMPLIANCES:****UL Recognized Component, File #E179259**

Recognized to U.S. and Canadian requirements under the Component Recognition Program of Underwriters Laboratories, Inc.

**SAFETY**

EN 61010-1, IEC 1010-1  
 Safety requirements for electrical equipment for measurement, control, and laboratory use, Part I

**ELECTROMAGNETIC COMPATIBILITY****Immunity to EN 50082-2**

Electrostatic discharge	EN 61000-4-2	Level 3; 8 Kv air
Electromagnetic RF fields	EN 61000-4-3	Level 3; 10 V/m <sup>1</sup> 80 MHz - 1 GHz
Fast transients (burst)	EN 61000-4-4	Level 4; 2 Kv I/O Level 3; 2 Kv power
RF conducted interference	EN 61000-4-6	Level 3; 10 V/rms 150 KHz - 80 MHz
Simulation of cordless telephones	ENV 50204	Level 3; 10 V/m 900 MHz $\pm$ 5 MHz 200 Hz, 50% duty cycle

**Emissions to EN 50081-2**

RF interference	EN 55011	Enclosure class A Power mains class A
-----------------	----------	--

*Notes:*

1. *Self-recoverable loss of performance during EMI disturbance at 10 V/m: Measurement error less than 2% of full scale.*  
 For operation without loss of performance:  
 Mount unit in a metal enclosure (Buckeye SM7013-0 or equivalent)  
 Route power and I/O cables in metal conduit connected to earth ground.

**22. CONNECTIONS:** High compression cage-clamp terminal block

Wire Strip Length: 0.3" (7.5 mm)  
 Wire Gauge Capacity: One 14 AWG (2.55 mm) solid, two 18 AWG (1.02 mm), or four 20 AWG (0.61 mm).

**23. CONSTRUCTION:** This unit is rated for NEMA 4X/IP65 indoor use. IP20 Touch safe. Installation Category II, Pollution Degree 2. One piece bezel/case. Flame resistant. Synthetic rubber keypad. Panel gasket and mounting clip included.**24. WEIGHT:** 10.4 oz. (295 g)

## ORDERING INFORMATION

TYPE	MODEL NO.	DESCRIPTION	PART NUMBERS
Meter	PAXT	Thermocouple and RTD Panel Meter, Upgradeable, AC Powered	PAXT0000
		Thermocouple and RTD Panel Meter, Upgradeable, DC Powered	PAXT0010
Optional Plug-In Cards	PAXCDS	Dual Setpoint Relay Output Card	PAXCDS10
		Quad Setpoint Relay Output Card	PAXCDS20
		Quad Setpoint Sinking Open Collector Output Card	PAXCDS30
		Quad Setpoint Sourcing Open Collector Output Card	PAXCDS40
	PAXCDC	RS485 Serial Communications Card	PAXCDC10
		RS232 Serial Communications Card	PAXCDC20
		MODBUS Communications Card	PAXCDC40
PAXCDL	Analog Output Card	PAXCDL10	
Accessories	PAXLBK	Units Label Kit Accessory	PAXLBK10
	SFPAX	PC Configuration Software for Windows 3.x and 95 (3.5" disk)	SFPAX

# OPTIONAL PLUG-IN CARDS AND ACCESSORIES

The PAX series meters can be fitted with up to three optional plug-in cards. However, only one card from each function type can be installed at a time. The function types include Setpoint Alarms (PAXCDS), Communications (PAXCDC), and Analog Output (PAXCDL). The cards can be installed initially or at a later date. Each optional plug-in card is shipped with complete installation and programming instructions.

## SETPOINT ALARMS PLUG-IN CARDS (PAXCDS)

The PAX series has four setpoint alarm output plug-in cards. Only one of these cards can be installed at a time. (Logic state of the outputs can be reversed in the programming.) These plug-in cards include:

- Dual relay, FORM-C, Normally open & closed
- Quad relay, FORM-A, Normally open only
- Isolated quad sinking NPN open collector
- Isolated quad sourcing PNP open collector

## SERIAL RS485 PLUG-IN CARD (PAXCDC)

An RS485 communication port can be installed with the serial RS485 plug-in card. The RS485 option allows the connection of up to 32 meters or other devices (such as a printer, PLC, HMI, or a host computer) on a single pair of wires not longer than 4,000 feet. The address number of each meter on the line can be programmed from 0-99. Data from the meter(s) can be interrogated or changed and alarm outputs can be reset by sending the proper command string. The function keys and user inputs can be programmed to send data to a printer or other device via serial communications.

## SERIAL RS232 PLUG-IN CARD (PAXCDC)

An RS232 communication port can be installed with the serial RS232 plug-in card. The RS232 is intended to allow only 2 devices, not more than 50 feet apart, to communicate to each other (such as a printer, PLC, HMI, or host computer). Data from the meter(s) can be interrogated or changed and alarm outputs can be reset by sending the proper command string. The function keys and user inputs can be programmed to send data to a printer or device via serial communication.

## MODBUS PLUG-IN CARD (PAXCDC)

A MODBUS communication port can be installed with the MODBUS plug-in card. The MODBUS card uses standard MODBUS protocol, which allows the integration of devices of different types and manufacturers within a common communication framework.

## ANALOG OUTPUT PLUG-IN CARD (PAXCDL)

Either a 0(4)-20 mA or 0-10 V retransmitted linear DC output is available from the analog output plug-in card. The programmable output low and high scaling can be based on the input max, min, or total display value. Reverse acting output is possible by reversing the scaling point positions.

## UNITS LABEL KIT (PAXLBK)

Each meter comes with °F and °C overlay labels which can be installed into the meter's bezel display assembly. The backlight for the labels is controlled in the programming. Additional custom units are available in the Units Label Kit.

## PC SOFTWARE (SFPAX)

The SFPAX is a Windows based program that allows configuring of the PAX meter from a PC. Using SFPAX makes it easier to program the PAX meter and allows saving the PAX program in a PC file for future use. On-line help is available within the software. A PAX serial plug-in card is required to program the meter using the software.

## TEMPERATURE SENSOR PROBES

Thermocouple and RTD temperature probes are available. These probes are field cuttable to the desired length. Accessory hardware is available to wire and mount the probes in the user's existing thermowells.

## 1.0 INSTALLING THE METER

### Installation

The PAX meets NEMA 4X/IP65 requirements for indoor use when properly installed. The unit is intended to be mounted into an enclosed panel. Prepare the panel cutout to the dimensions shown. Remove the panel latch and cardboard sleeve from the unit and discard the cardboard sleeve. Slide the panel gasket over the rear of the unit to the back of the bezel.

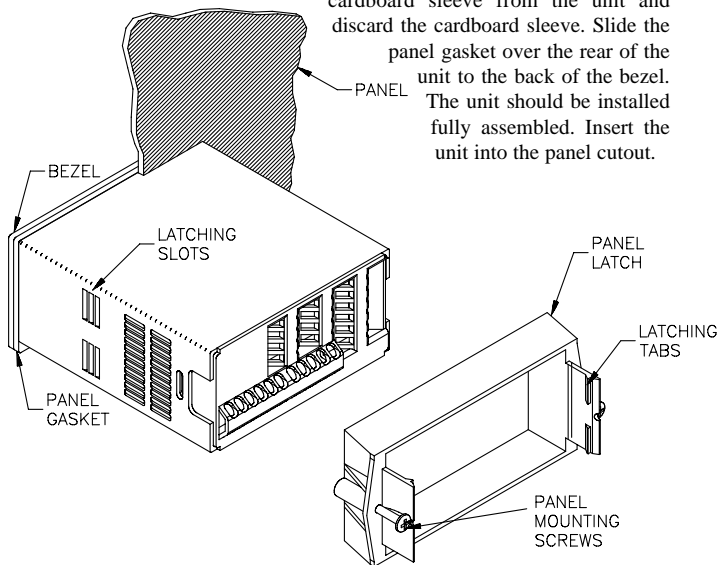

While holding the unit in place, push the panel latch over the rear of the unit so that the tabs of the panel latch engage in the slots on the case. The panel latch should be engaged in the farthest forward slot possible. To achieve a proper seal, tighten the latch screws evenly until the unit is snug in the panel (Torque to approximately 7 in-lbs [79N-cm]). Do not over-tighten the screws.

### Installation Environment

The unit should be installed in a location that does not exceed the maximum operating temperature and provides good air circulation. Placing the unit near devices that generate excessive heat should be avoided.

The bezel should be cleaned only with a soft cloth and neutral soap product. Do NOT use solvents. Continuous exposure to direct sunlight may accelerate the aging process of the bezel.

Do not use tools of any kind (screwdrivers, pens, pencils, etc.) to operate the keypad of the unit.

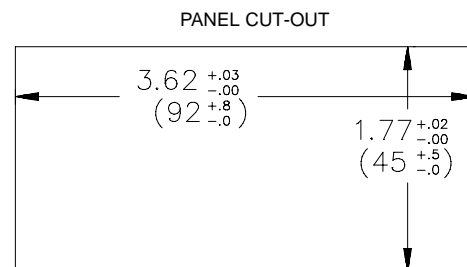

## 2.0 SETTING THE JUMPERS

The meter has two jumpers that must be checked and / or changed prior to applying power. The two jumpers are: RTD Input and User Input Logic. The figure on the right is an enlargement of the jumper area below.

To access the jumpers, remove the meter base from the meter case by firmly squeezing and pulling back on the side rear finger tabs. This should lower the latch below the case slot (which is located just in front of the finger tabs). It is recommended to release the latch on one side, then start the other side latch.

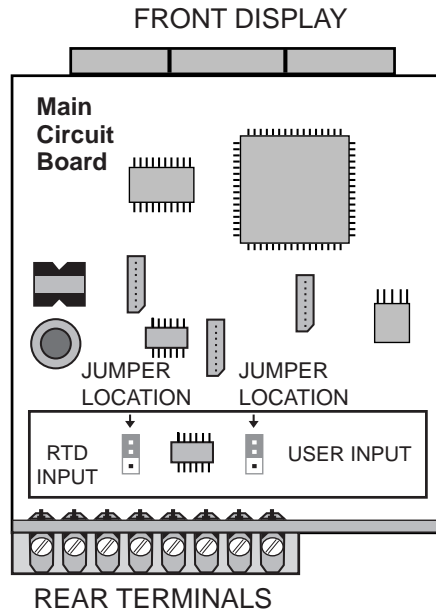

### RTD Input Jumper

One jumper is used for RTD input ranges. Select the proper range to match the RTD probe being used. It is not necessary to remove this jumper when not using RTD probes.

### User Input Logic Jumper

One jumper is used for the logic state of all user inputs. If the user inputs are not used, it is not necessary to check or move this jumper.

### JUMPER SELECTIONS

The  $\sphericalangle$  indicates factory setting.

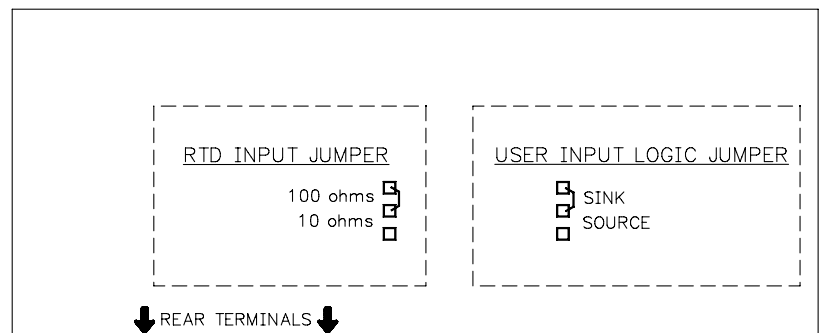

## 3.0 WIRING THE METER

### WIRING OVERVIEW

Electrical connections are made via screw-clamp terminals located on the back of the meter. All conductors should conform to the meter's voltage and current ratings. All cabling should conform to appropriate standards of good installation, local codes and regulations. It is recommended that power supplied to the meter (DC or AC) be protected by a fuse or circuit breaker.

When wiring the meter, compare the numbers embossed on the back of the meter case against those shown in wiring drawings for proper wire position. Strip the wire, leaving approximately 0.3" (7.5 mm) bare lead exposed (stranded wires should be tinned with solder). Insert the lead under the correct screw-clamp terminal and tighten until the wire is secure. (Pull wire to verify tightness.) Each terminal can accept up to one #14 AWG (2.55 mm) wire, two #18 AWG (1.02 mm), or four #20 AWG (0.61 mm).

### EMC INSTALLATION GUIDELINES

Although this meter is designed with a high degree of immunity to Electro-Magnetic Interference (EMI), proper installation and wiring methods must be followed to ensure compatibility in each application. The type of the electrical noise, source or coupling method into the unit may be different for various installations. The unit becomes more immune to EMI with fewer I/O connections. Cable length, routing and shield termination are very important and can mean the difference between a successful or a troublesome installation. Listed below are some EMC guidelines for successful installation in an industrial environment.

1. The meter should be mounted in a metal enclosure, which is properly connected to protective earth.
2. Use shielded (screened) cables for all Signal and Control inputs. The shield (screen) pigtail connection should be made as short as possible. The connection point for the shield depends somewhat upon the application. Listed below are the recommended methods of connecting the shield, in order of their effectiveness.
  - a. Connect the shield only at the panel where the unit is mounted to earth ground (protective earth).

- b. Connect the shield to earth ground at both ends of the cable, usually when the noise source frequency is above 1 MHz.
- c. Connect the shield to common of the unit and leave the other end of the shield unconnected and insulated from earth ground.

3. Never run Signal or Control cables in the same conduit or raceway with AC power lines, conductors feeding motors, solenoids, SCR controls, and heaters, etc. The cables should be run in metal conduit that is properly grounded. This is especially useful in applications where cable runs are long and portable two-way radios are used in close proximity or if the installation is near a commercial radio transmitter.
4. Signal or Control cables within an enclosure should be routed as far away as possible from contactors, control relays, transformers, and other noisy components.
5. In extremely high EMI environments, the use of external EMI suppression devices, such as ferrite suppression cores, is effective. Install them on Signal and Control cables as close to the unit as possible. Loop the cable through the core several times or use multiple cores on each cable for additional protection. Install line filters on the power input cable to the unit to suppress power line interference. Install them near the power entry point of the enclosure. The following EMI suppression devices (or equivalent) are recommended:

Ferrite Suppression Cores for signal and control cables:

Fair-Rite # 0443167251 (RLC #FCOR0000)

TDK # ZCAT3035-1330A

Steward #28B2029-0A0

Line Filters for input power cables:

Schaffner # FN610-1/07 (RLC #LFIL0000)

Schaffner # FN670-1.8/07

Corcom #1VR3

*Note: Reference manufacturer's instructions when installing a line filter.*

6. Long cable runs are more susceptible to EMI pickup than short cable runs. Therefore, keep cable runs as short as possible.
7. Switching of inductive loads produces high EMI. Use of snubbers across inductive loads suppresses EMI.  
Snubber: RLC#SNUB0000.

### 3.1 POWER WIRING

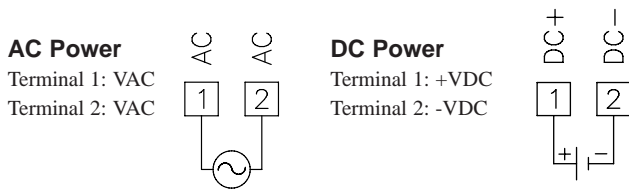

### 3.2 INPUT SIGNAL WIRING

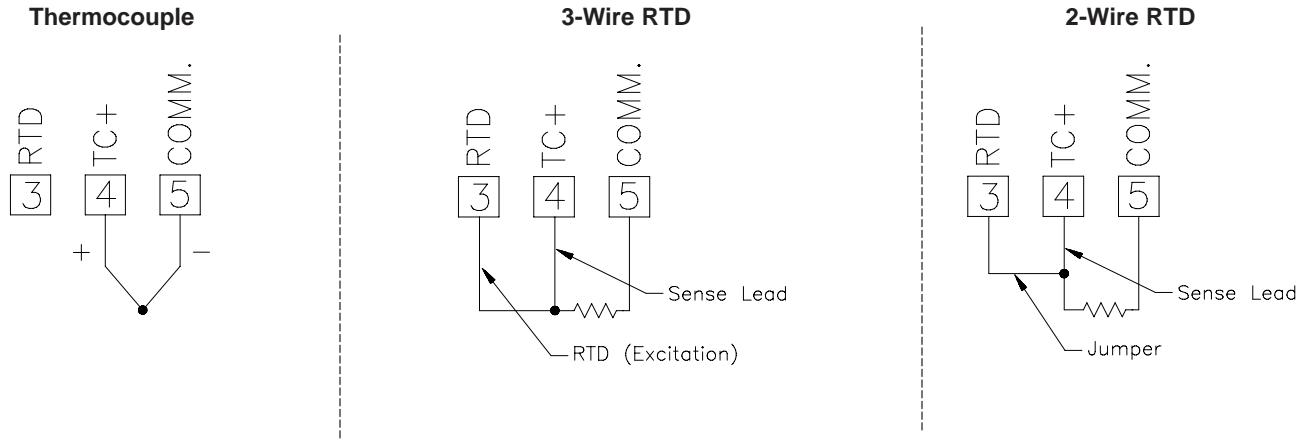

**CAUTION:** Sensor input common is *NOT* isolated from user input common. In order to preserve the safety of the meter application, the sensor input common must be suitably isolated from hazardous live earth referenced voltages; or input common must be at protective earth ground potential. If not, hazardous live voltage may be present at the User Inputs and User Input Common terminals. Appropriate considerations must then be given to the potential of the user input common with respect to earth common; and the common of the isolated plug-in cards with respect to input common.

### 3.3 USER INPUT WIRING

Before connecting the wires, the User Input Logic Jumper should be verified for proper position. If not using User Inputs, then skip this section. Only the appropriate User Input terminal has to be wired.

#### Sinking Logic

Terminal 8-10: } Connect external switching device between  
Terminal 7: } appropriate User Input terminal and User Comm.

In this logic, the user inputs of the meter are internally pulled up to +5 V with 22 K resistance. The input is active when it is pulled low (<0.7 V).

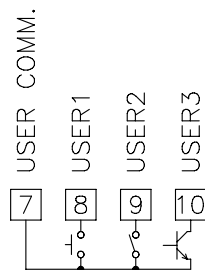

#### Sourcing Logic

Terminal 8-10: + VDC thru external switching device  
Terminal 7: -VDC thru external switching device

In this logic, the user inputs of the meter are internally pulled down to 0 V with 22 K resistance. The input is active when a voltage greater than 2.5 VDC is applied.

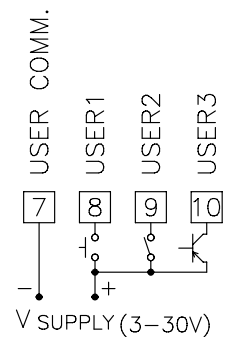

### 3.4 SETPOINT (ALARMS) WIRING

### 3.5 SERIAL COMMUNICATION WIRING

### 3.6 ANALOG OUTPUT WIRING

See appropriate plug-in card bulletin for details.

## 4.0 REVIEWING THE FRONT BUTTONS AND DISPLAY

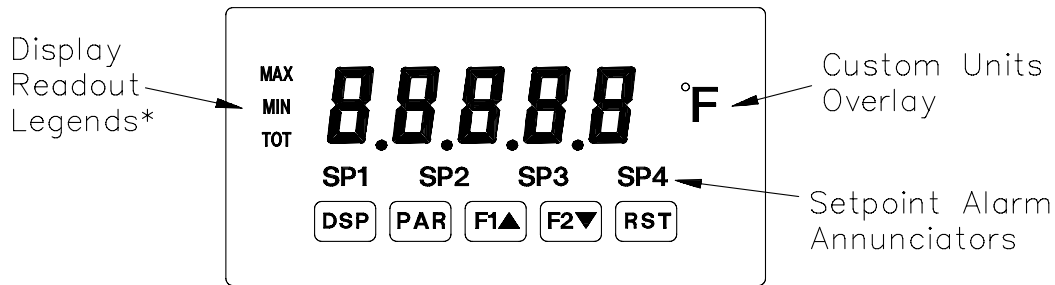

### KEY DISPLAY MODE OPERATION

<b>DSP</b>	Index display through max/min/total/input readouts
<b>PAR</b>	Access parameter list
<b>F1▲</b>	Function key 1; hold for 3 seconds for Second Function 1
<b>F2▼</b>	Function key 2; hold for 3 seconds for Second Function 2
<b>RST</b>	Reset (Function key)**

\* Display Readout Legends may be locked out in Factory Settings.  
 \*\* Factory setting for the F1, F2, and RST keys is NO mode.

### PROGRAMMING MODE OPERATION

	Quit programming and return to display mode
	Store selected parameter and index to next parameter
	Increment selected parameter value
	Decrement selected parameter value
	Hold with F1▲, F2▼ to scroll value by x1000

## 5.0 PROGRAMMING THE METER

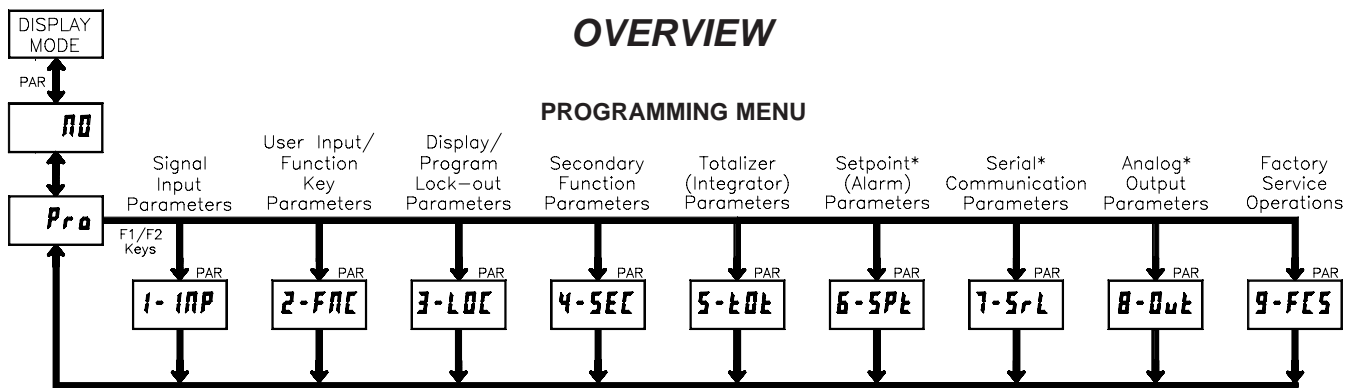

### PROGRAMMING MODE ENTRY (PAR KEY)

The Display Mode is the normal operating mode of the meter. The Programming Mode is entered by pressing the **PAR** key. If it is not accessible, then it is locked by either a security code, or a hardware lock.

### PARAMETER MODULE ENTRY (ARROW & PAR KEYS)

The Programming Menu is organized into modules. These modules group together parameters which are related in function. The display will alternate between **Pr0** and the current parameter module. The arrow keys (**F1** and **F2**) are used to select the desired parameter module. The displayed module is entered by pressing the **PAR** key.

### PARAMETER MENU MOVEMENT (PAR KEY)

Each parameter module has a separate module menu (which is shown at the start of each parameter module discussion). The **PAR** key is pressed to advance to a particular parameter without changing the programming of preceding parameters. After completing a module, the display will return to **Pr0**. Programming may continue by accessing additional parameter modules.

### SELECTION/VALUE ENTRY (ARROW & PAR KEYS)

In the parameter module, the display will alternate between the current parameter and the selections/values for that parameter. The arrow keys (**F1** and **F2**) are used to move through the selections/values for that parameter. By pressing the **PAR** key, the displayed selection is stored and activated. This will also advance the meter to the next parameter.

### PROGRAMMING MODE EXIT (DSP KEY or at Pr0 PAR KEY)

The Programming Mode is exited by pressing the **DSP** key (from anywhere in the Programming Mode) or the **PAR** key (with **Pr0** displayed). This will commit any stored parameter changes to memory and return the meter to the Display Mode. If a parameter was just changed, the **PAR** key should be pressed to store the change before pressing the **DSP** key. (If power loss occurs before returning to the Display Mode, verify recent parameter changes.)

### PROGRAMMING TIPS

It is recommended to start with Parameter Module 1. If lost or confused while programming, press the **DSP** key and start over. When programming is complete, it is recommended to record the parameter programming on the Parameter User Chart and lock-out parameter programming with a user input or lock-out code.

### FACTORY SETTINGS

Factory Settings may be completely restored in Parameter Module 9. This is a good starting point for programming problems. Some parameters can be left at their Factory Settings without affecting basic start-up. These parameters are identified throughout the module explanations. Try the settings unless a specific selection or value is known.

### ALTERNATING SELECTION DISPLAY

In the explanation of the parameter modules, the following dual display with arrows will appear. It is to illustrate the display alternating between the parameter on top, and the parameter's Factory Setting on the bottom. In most cases, selections and values for the parameter will be listed on the right. Factory Settings may have a different decimal point location than what is listed.

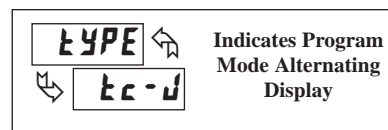

# 5.1 MODULE 1 - Signal Input Parameters (I- INP)

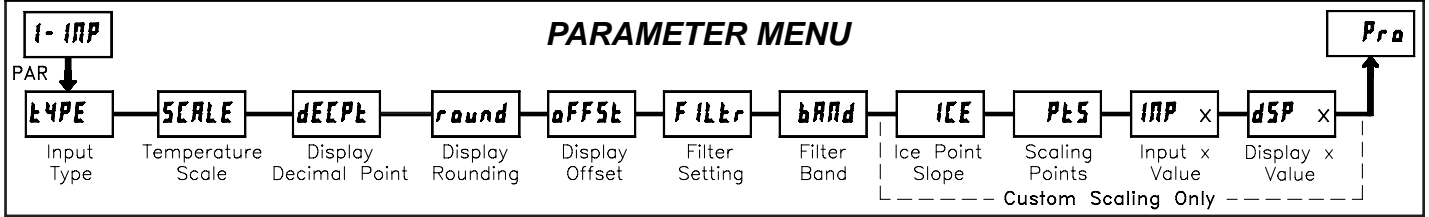

## INPUT TYPE

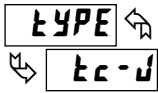

SELECTION	TYPE	SELECTION	TYPE
TC-T	T TC	TC-C	C TC
TC-E	E TC	PL385	RTD platinum 385
TC-U	J TC	PL392	RTD platinum 392
TC-K	K TC	N1672	RTD nickel 672
TC-R	R TC	C1427	RTD copper 10 Ω
TC-S	S TC	CS-TC	Custom TC
TC-B	B TC	CS-rH	Custom RTD High
TC-N	N TC	CS-rL	Custom RTD Low

Select the input type that corresponds to the input sensor. For RTD types, check the RTD Input Jumper for matching selection. For custom types, the Temperature Scale parameter is not available, the Display Decimal Point is expanded, and Custom Sensor Scaling must be completed.

## TEMPERATURE SCALE



°F    °C

Select the temperature scale. This selection applies to for Input, MAX, MIN, and TOT displays. This does not change the user installed Custom Units Overlay display. If changed, those parameters that relate to the temperature scale should be checked. This selection is not available for custom sensor types.

## DISPLAY DECIMAL POINT



0    00    000    0000    00000

Custom Scaling Only

Select the decimal point location for the Input, MAX and MIN displays. (The TOT display decimal point is a separate parameter.) This selection also affects round, dSP1 and dSP2 parameters and setpoint values.

## DISPLAY ROUNDING\*



1    2    5

Rounding selections other than one, cause the Input Display to 'round' to the nearest rounding increment selected (ie. rounding of '5' causes 122 to round to 120 and 123 to round to 125). Rounding starts at the least significant digit. Position of the decimal point should be ignored when programming this selection. Remaining parameter entries (scaling point values, setpoint values, etc.) are not automatically adjusted to this display rounding selection.

## TEMPERATURE DISPLAY OFFSET\*



- 99999 to 99999

The temperature display can be corrected with an offset value. This can be used to compensate for probe errors, errors due to variances in probe placement or adjusting the readout to a reference thermometer. This value is automatically updated after a Zero Display to show how far the display is offset. A value of zero will remove the affects of offset.

## FILTER SETTING\*

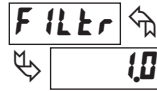

00 to 250 seconds

The input filter setting is a time constant expressed in tenths of a second. The filter settles to 99% of the final display value within approximately 3 time constants. This is an Adaptive Digital Filter which is designed to steady the Input Display reading. A value of '0' disables filtering.

## FILTER BAND\*



0 to 250 degrees

The digital filter will adapt to variations in the input signal. When the variation exceeds the input filter band value, the digital filter disengages. When the variation becomes less than the band value, the filter engages again. This allows for a stable readout, but permits the display to settle rapidly after a large process change. The value of the band is in display units, independent of the Display Decimal Point position. A band setting of '0' keeps the digital filter permanently engaged.

The following parameters only apply to Custom Sensor Scaling.

## ICE POINT SLOPE

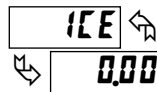

0 to 65000 μV/°C

This parameter sets the slope value for ice point compensation for the Custom TC range (CS-TC) only. The fixed thermocouple ranges are automatically compensated by the meter and do not require this setting. To calculate this slope, use μV data obtained from thermocouple manufacturers' tables for two points between 0°C and 50°C. Place this corresponding μV and °C information into the equation:

$$\text{slope} = (\mu V_2 - \mu V_1) / (C_2 - C_1)$$

Due to the nonlinear output of thermocouples, the compensation may show a small offset error at room temperatures. This can be compensated by the offset parameter. A value of 0 disables internal compensation when the thermocouple is externally compensated.

## SCALING POINTS

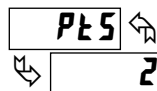

2 to 16

### Linear - Scaling Points (2)

For linear processes, only 2 scaling points are necessary. It is recommended that the 2 scaling points be at opposite ends of the input signal being applied. The points do not have to be the signal limits. Display scaling will be linear between and continue past the entered points up to the limits of the Input Signal Jumper position. Each scaling point has a coordinate-pair of Input Value (INP) and an associated desired Display Value (dSP).

### Nonlinear - Scaling Points (Greater than 2)

For non-linear processes, up to 16 scaling points may be used to provide a piece-wise linear approximation. (The greater the number of scaling points used, the greater the conformity accuracy.) The Input Display will be linear between scaling points that are sequential in program order. Each scaling point has a coordinate-pair of Input Value (INP) and an associated desired Display Value (dSP). Data from tables or equations, or empirical data could be used to derive the required number of segments and data values for the coordinate pairs.

\* Factory Setting can be used without affecting basic start-up.

### INPUT VALUE FOR SCALING POINT 1

**INP 1** - 19999 to 19999  
 1000  
 Enter the known second Input Value by using the arrow keys.  
 Do not exceed the listed limits for the selected custom range.

Probe Type	Input Range	Sensitivity
Thermocouples	-10.000 mV to 65.000 mV	1 $\mu$ V
RTD high ohms	0.00 to 400.00 ohms	5 Mohms
RTD low ohms	0.000 to 25.000 ohms	0.5 Mohms

### DISPLAY VALUE FOR SCALING POINT 1

**dSP 1** - 19999 to 19999  
 0  
 Enter the first coordinating Display Value by using the arrow keys. The decimal point follows the **dECPt** selection.

### INPUT VALUE FOR SCALING POINT 2

**INP 2** - 19999 to 19999  
 1000  
 Enter the known second Input Value by using the arrow keys. (Follow the same procedure, if using more than 2 scaling points.)  
 Do not exceed the listed limits for the selected custom range. (See table under Input Value for Scaling Point 1.)

### DISPLAY VALUE FOR SCALING POINT 2

**dSP 2** - 19999 to 19999  
 1000  
 Enter the second coordinating Display Value by using the arrow keys. (Follow the same procedure, if using more than 2 scaling points.)

### General Notes on Scaling

1. Input Values for scaling points must be confined to the limits of the Input type.
2. The difference between entered Input Values should be greater than the selected custom range sensitivity.
3. The same Input Value should not correspond to more than one Display Value. This is referred to as read out jumps (vertical scaled segments).
4. The same Display Value can correspond to more than one Input Value. This is referred to as readout dead zones (horizontal scaled segments).
5. The maximum scaled Display Value spread between range maximum and minimum is limited to 65,535.
6. For input levels beyond the first programmed Input Value, the meter extends the Display Value by calculating the slope from the first two coordinate pairs (**INP 1 / dSP 1** & **INP 2 / dSP 2**). The calculations stop at the limits of the Input type.
7. For input levels beyond the last programmed Input Value, the meter extends the Display Value by calculating the slope from the last two sequential coordinate pairs. If three coordinate pair scaling points were entered, then the Display Value calculation would be between **INP 2 / dSP 2** & **INP 3 / dSP 3**. The calculations stop at the limits of the Input type.

## 5.2 MODULE 2 - User Input and Front Panel Function Key Parameters (2-FNC)

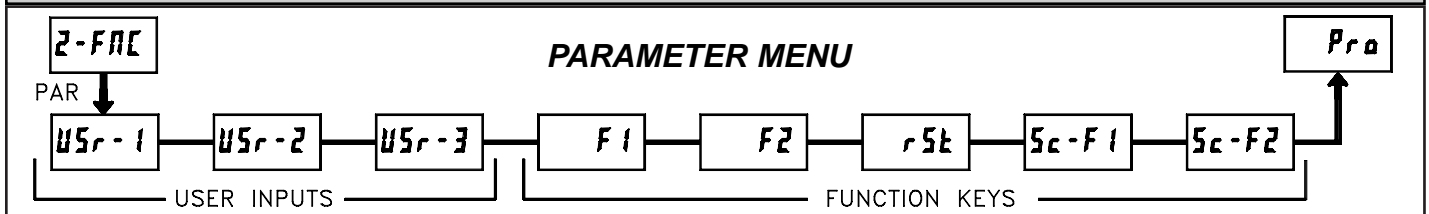

The three user inputs are individually programmable to perform specific meter control functions. While in the Display Mode or Program Mode, the function is executed the instant the user input transitions to the active state.

The front panel function keys are also individually programmable to perform specific meter control functions. While in the Display Mode, the primary function is executed the instant the key is pressed. Holding the function key for three seconds executes a secondary function. It is possible to program a secondary function without a primary function.

In most cases, if more than one user input and/or function key is programmed for the same function, the maintained (level trigger) actions will be performed while at least one of those user inputs or function keys are activated. The momentary (edge trigger) actions will be performed every time any of those user inputs or function keys transition to the active state.

**Note:** In the following explanations, not all selections are available for both user inputs and front panel function keys. Alternating displays are shown with each selection. Those selections showing both displays are available for both. If a display is not shown, it is not available for that selection. **USr-1** will represent all three user inputs. **F1** will represent all five function keys.

### NO FUNCTION

**USr-1** → **NO**      **F1** → **NO**

No function is performed if activated. This is the factory setting for all user inputs and function keys. No function can be selected without affecting basic start-up.

### PROGRAMMING MODE LOCK-OUT

**USr-1** → **PLOC**  
 Programming Mode is locked-out, as long as activated (maintained action). A security code can be configured to allow programming access during lock-out.

### ZERO DISPLAY

**USr-1** → **rEL**      **F1** → **rEL**

The Zero Display provides a way to zero the Input Display value at various input levels, causing future Display readings to be offset. When activated (momentary action), **rESEt** flashes and the Display is set to zero. At the same time, the Display value (that was on the display before the Zero Display) is subtracted from the Display Offset Value and is automatically stored as the new Display Offset Value (**oFFSt**). If another Zero Display is performed, the display will again change to zero and the Display reading will shift accordingly.

### RELATIVE/ABSOLUTE DISPLAY

**USr-1** → **d-rEL**      **F1** → **d-rEL**

This function switches the Input Display between Relative and Absolute. The Relative is a net value that includes the Display Offset Value. The Input Display will normally show the Relative unless switched by this function. Regardless of the display selected, all meter functions continue to operate based on relative values. The Absolute is a gross value (based on Module 1 **DSP** and **INP** entries) without the Display Offset Value. The input display switches to Absolute display as long as the user input is activated (maintained action) or at the transition of the function key (momentary action). When the user input is released, or the function key is pressed again, the input display switches back to Relative display. **AbS** (absolute) or **rEL** (relative) is momentarily displayed at transition to indicate which display is active.

### HOLD DISPLAY

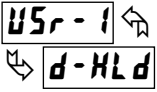

The shown display is held but all other meter functions continue as long as activated (maintained action).

### HOLD ALL FUNCTIONS

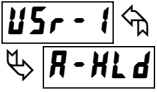

The meter disables processing the input, holds all display contents, and locks the state of all outputs as long as activated (maintained action). The serial port continues data transfer.

### SYNCHRONIZE METER READING

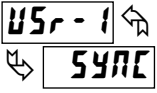

The meter suspends all functions as long as activated (maintained action). When the user input is released, the meter synchronizes the restart of the A/D with other processes or timing events.

### STORE BATCH READING IN TOTALIZER

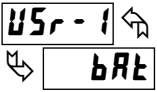

The Input Display value is one time added (batched) to the Totalizer at transition to activate (momentary action). The Totalizer retains a running sum of each batch operation until the Totalizer is reset. When this function is selected, the normal operation of the Totalizer is overridden.

### SELECT TOTALIZER DISPLAY

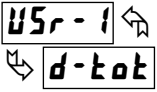

The Totalizer display is selected as long as activated (maintained action). When the user input is released, the Input Display is returned. The DSP key overrides the active user input. The Totalizer continues to function including associated outputs independent of being displayed.

### RESET TOTALIZER

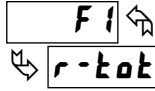
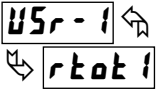

When activated (momentary action), rESEt flashes and the Totalizer resets to zero. The Totalizer then continues to operate as it is configured. This selection functions independent of the selected display.

### RESET AND ENABLE TOTALIZER

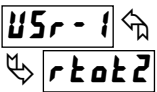

When activated (momentary action), rESEt flashes and the Totalizer resets to zero. The Totalizer continues to operate as it is configured while active (maintained action). When the user input is released, the Totalizer stops and holds its value. This selection functions independent of the selected display.

### ENABLE TOTALIZER

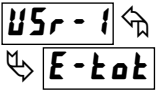

The Totalizer continues to operate as long as activated (maintained action). When the user input is released, the Totalizer stops and holds its value. This selection functions independent of the selected display.

### SELECT MAXIMUM DISPLAY

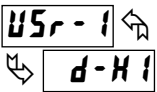

The Maximum display is selected as long as activated (maintained action). When the user input is released, the Input Display returns. The DSP key overrides the active user input. The Maximum continues to function independent of being displayed.

### RESET MAXIMUM

When activated (momentary action), rESEt flashes and the Maximum resets to the present Input Display value. The Maximum function then continues from that value. This selection functions independent of the selected display.

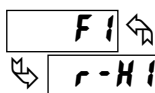

### RESET, SELECT, ENABLE MAXIMUM DISPLAY

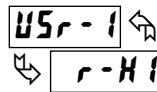

When activated (momentary action), the Maximum value resets to the present Input Display value. The Maximum continues from that value while active (maintained action). When the user input is released, the Maximum stops and holds its value. This selection functions independent of the selected display. The DSP key overrides the display activated by the user input, but not the Maximum function.

### SELECT MINIMUM DISPLAY

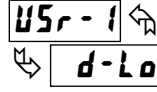

The Minimum display is selected as long as activated (maintained action). When the user input is released, the Input Display returns. The DSP key overrides the active user input. The Minimum continues to function independent of being displayed.

### RESET MINIMUM

When activated (momentary action), rESEt flashes and the Minimum resets to the present Input Display value. The Minimum function then continues from that value. This selection functions independent of the selected display.

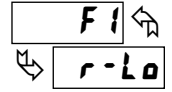

### RESET, SELECT, ENABLE MINIMUM DISPLAY

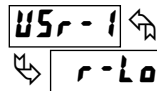

When activated (momentary action), the Minimum value resets to the present Input Display value. The Minimum continues from that value while active (maintained action). When the user input is released, the Minimum stops and holds its value. This selection functions independent of the selected display. The DSP key overrides the display activated by the user input, but not the Minimum function.

### RESET MAXIMUM AND MINIMUM

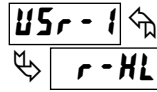

When activated (momentary action), rESEt flashes and the Maximum and Minimum resets to the present Input Display value. The Maximum and Minimum function then continues from that value. This selection functions independent of the selected display.

### SETPOINT SELECTIONS

The following selections are accessible only with the Setpoint plug-in card installed. Refer to the Setpoint Card Bulletin shipped with the Setpoint Plug-in card, for explanation of their operation.

Setpoint Card Only

- L 15t - Select main or alternate setpoints
- r-1 - Reset Setpoint 1 (Alarm 1)
- r-2 - Reset Setpoint 2 (Alarm 2)
- r-3 - Reset Setpoint 3 (Alarm 3)
- r-4 - Reset Setpoint 4 (Alarm 4)
- r-34 - Reset Setpoint 34 (Alarm 34)
- r-234 - Reset Setpoint 234 (Alarm 234)
- r-ALL - Reset Setpoint All (Alarm All)

### PRINT REQUEST

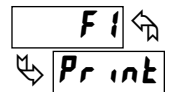
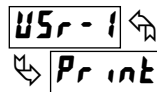

The meter issues a block print through the serial port when activated. The data transmitted during a print request is programmed in Module 7. If the user input is still active after the transmission is complete (about 100 msec), an additional transmission occurs. As long as the user input is held active, continuous transmissions occur.

## 5.3 MODULE 3 - Display and Program Lock-out Parameters (3-LOC)

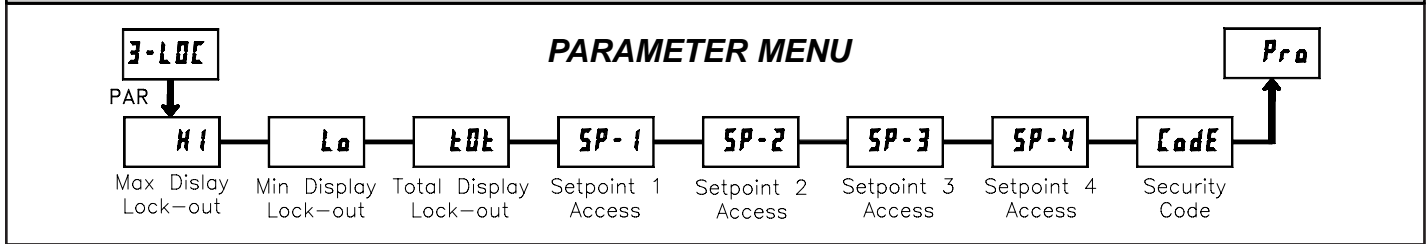

**MAXIMUM DISPLAY LOCK-OUT\***  
**MINIMUM DISPLAY LOCK-OUT\***  
**TOTALIZER DISPLAY LOCK-OUT\***

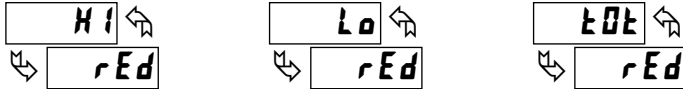

These displays can be programmed for **LOC** or **rEd**. When programmed for **LOC**, the display will not be shown when the **DSP** key is pressed regardless of Program Lock-out status. It is suggested to lock-out the display if it is not needed. The associated function will continue to operate even if its display is locked-out.

**SP-1 SP-2 SP-3 SP-4 SETPOINT ACCESS\***

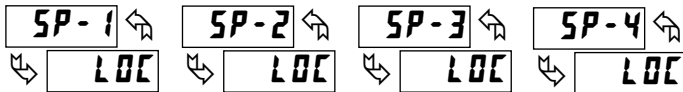

The setpoint displays can be programmed for **LOC**, **rEd** or **Ent** (See following table). Accessible only with the Setpoint plug-in card installed.

Selection	Description
<b>LOC</b>	Not visible in Display Mode.
<b>rEd</b>	Visible, but not changeable in Display Mode during Program Lock-out.
<b>Ent</b>	Visible and changeable in Display Mode during Program Lock-out.

**PROGRAM MODE SECURITY CODE\***

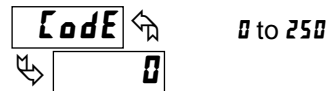

By entering any non-zero value, the prompt **Code 0** will appear when trying to access the Program Mode. Access will only be allowed after entering a matching security code or universal code of **222**. With this lock-out, a user input would not have to be configured for Program Lock-out. However, this lock-out is overridden by an inactive user input configured for Program Lock-out.

\* *Factory Setting can be used without affecting basic start-up.*

## 5.4 MODULE 4 - Secondary Function Parameters (4-SEC)

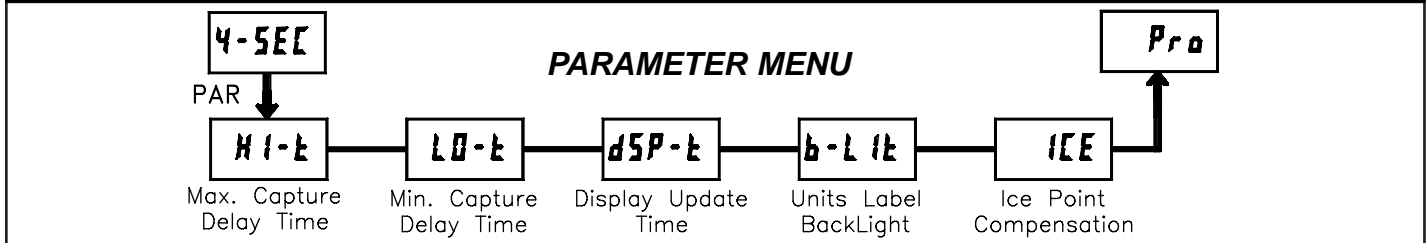

**MAX CAPTURE DELAY TIME\***

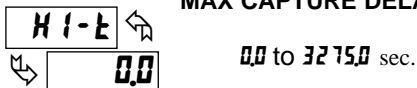

When the Input Display is above the present MAX value for the entered amount of time, the meter will capture that display value as the new MAX reading. A delay time helps to avoid false captures of sudden short spikes. A value of 0.0 allows an update rate per the Display Update Rate.

**MIN CAPTURE DELAY TIME\***

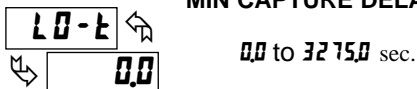

When the Input Display is below the present MIN value for the entered amount of time, the meter will capture that display value as the new MIN reading. A delay time helps to avoid false captures of sudden short spikes. A value of 0.0 allows an update rate per the Display Update Rate.

**DISPLAY UPDATE RATE\***

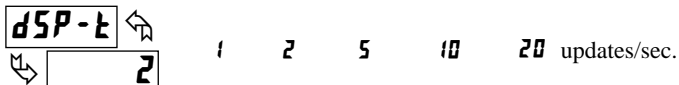

This parameter determines the rate of display update. When set to 20 updates/second it allows for the fastest possible output response.

**UNITS LABEL BACKLIGHT\***



The Units Label Kit Accessory contains a sheet of custom unit overlays which can be installed in to the meter's bezel display assembly. The backlight for these custom units is activated by this parameter.

**ICE POINT COMPENSATION\***



This parameter turns the internal ice point compensation on or off. Normally, the ice point compensation is on. If using external compensation, set this parameter to off. In this case, use copper leads from the external compensation point to the meter. If using Custom TC range, the ice point compensation can be adjusted by a value in Module 1 when this is yes.

\* *Factory Setting can be used without affecting basic start-up.*

# 5.5 MODULE 5 - Totalizer (Integrator) Parameters (5-606)

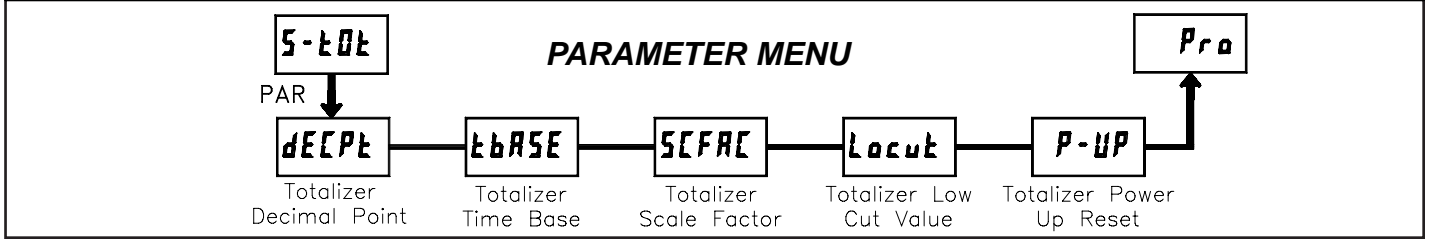

The signal totalizer (integrator) can be used to compute a time-temperature product. This can be used to provide a readout of temperature integration, useful in curing and sterilization applications. The second is through a user input or function key programmed for Batch (one time add on demand). If the Totalizer is not needed, its display can be locked-out and this module can be skipped during programming.

### TOTALIZER DECIMAL POINT\*



For most applications, this matches the Input Display Decimal Point (dECPt). If a different location is desired, refer to Totalizer Scale Factor.

### TOTALIZER TIME BASE

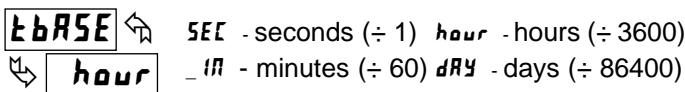

This is the time base used in Totalizer accumulations. If the Totalizer is being accumulated through a user input programmed for Batch, then this parameter does not apply.

### TOTALIZER SCALE FACTOR\*



For most applications, the Totalizer reflects the same decimal point location and engineering units as the Input Display. In these cases, the Totalizer Scale Factor is 1.000. The Totalizer Scale Factor can be used to scale the Totalizer to a different value than the Input Display. Common possibilities are:

1. Changing decimal point location (example tenths to whole)
2. Average over a controlled time frame.

Details on calculating the scale factor are shown later.

If the Totalizer is being accumulated through a user input programmed for Batch, then this parameter does not apply.

### TOTALIZER LOW CUT VALUE\*

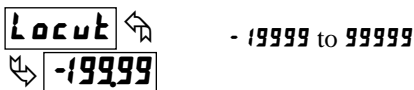

A low cut value disables Totalizer when the Input Display value falls below the value programmed.

### TOTALIZER POWER UP RESET\*

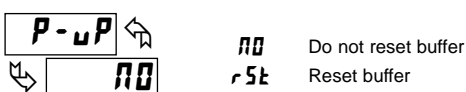

The Totalizer can be reset to zero on each meter power-up by setting this parameter to reset.

\* Factory Setting can be used without affecting basic start-up.

### TOTALIZER HIGH ORDER DISPLAY

When the total exceeds 5 digits, the front panel annunciator TOT flashes. In this case, the meter continues to totalize up to a 9 digit value. The high order 4 digits and the low order 5 digits of the total are displayed alternately. The letter "h" denotes the high order display.

### TOTALIZER BATCHING

The Totalizer Time Base and scale factor are overridden when a user input or function key is programmed for store batch (bAt). In this mode, when the user input or function key is activated, the Input Display reading is one time added to the Totalizer (batch). The Totalizer retains a running sum of each batch operation until the Totalizer is reset. This is useful in weighting operations, when the value to be added is not based on time but after a filling event.

### TOTALIZER USING TIME BASE

Totalizer accumulates as defined by:

$$\frac{\text{Input Display} \times \text{Totalizer Scale Factor}}{\text{Totalizer Time Base}}$$

Where:

- Input Display - the present input reading
- Totalizer Scale Factor - 0.001 to 65.000
- Totalizer Time Base - (the division factor of tBASE)

Example: The input reading is at an average of 10.0°C per hour. The Totalizer is used to verify this average reading in a controlled time frame of 4 hours. Because the Input Display and Totalizer are both in tenths of °C, the Totalizer Scale Factor is 1. However, the Totalizer Time Base is hours (3600) divided by the 4 hours in the controlled time frame to yield a Totalizer Scale Factor of 0.250. By placing these values in the equation, the Totalizer will accumulate every second as follows:

$$\frac{10.0 \times 0.250}{3600} = 0.00069 \text{ accumulates each second}$$

This results in:

- 0.04167 accumulates each minute
- 2.5 accumulates each hour
- 10.0 reached at the end of 4 hours

### TOTALIZER SCALE FACTOR CALCULATION EXAMPLES

1. When changing the Totalizer Decimal Point (dECPt) location from the Input Display Decimal Point (dECPt), the required Totalizer Scale Factor is multiplied by a power of ten.

Example: Input (dECPt)=0.0

Totalizer dECPt	Scale Factor
0.00	10
0.0	1
0	.1
x10	.01
x100	.001

Input (dECPt)= 0.00

Totalizer dECPt	Scale Factor
0.000	10
0.00	1
0.0	.1
0	.01
x10	.001

(x = Totalizer display is round by tens or hundreds)

2. To obtain an average reading within a controlled time frame, the selected Totalizer Time Base is divided by the given time period expressed in the same timing units.

Example: Average temperature per hour in a 4 hour period, the scale factor would be 0.250. To achieve a controlled time frame, connect an external timer to a user input programmed for rSt. The timer will control the start (reset) and the stopping (hold) of the totalizer.

Modules 6, 7, and 8 are accessible only with the appropriate plug-in cards installed. A quick overview of each Module is listed below. Refer to the corresponding plug-in card bulletin for a more detailed explanation of each parameter selection.

## 5.6 MODULE 6 - Setpoint (Alarm) Parameters (6-5Pt)

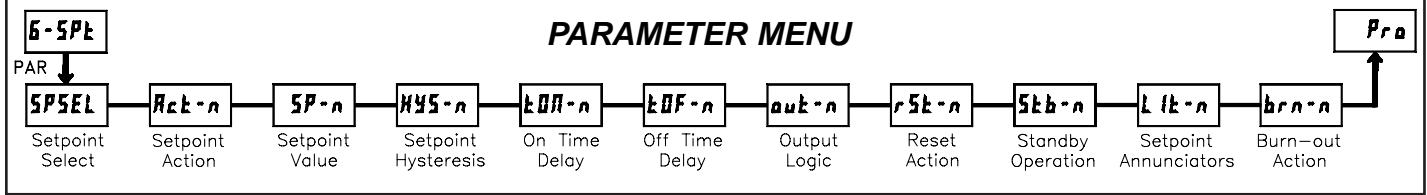

<b>SPSEL - SELECT SETPOINT</b>	<b>00 SP-1</b>	<b>SP-3</b>
	<b>SP-2</b>	<b>SP-4</b>
<b>Act-n - SETPOINT ACTION</b>	<b>OFF</b>	<b>dE-HI</b>
	<b>Ab-HI</b>	<b>dE-LO</b>
	<b>Ab-LO</b>	<b>brnd</b>
	<b>RU-HI</b>	<b>LoLk</b>
	<b>RU-LO</b>	<b>LoKH</b>
<b>SP-n - SETPOINT VALUE</b>	<b>-19999 to 99999</b>	
<b>HYS-n - SETPOINT HYSTERESIS</b>	<b>1 to 65000</b>	

<b>On-n - ON TIME DELAY</b>	<b>00 to 32750 sec</b>	
<b>Off-n - OFF TIME DELAY</b>	<b>00 to 32750 sec</b>	
<b>out-n - OUTPUT LOGIC</b>	<b>nor</b>	<b>rEu</b>
<b>rSt-n - RESET ACTION</b>	<b>RUto</b>	<b>LRtC2</b>
	<b>LRtC1</b>	
<b>Stb-n - STANDBY OPERATION</b>	<b>00</b>	<b>YES</b>
<b>Ltk-n - SETPOINT ANNUNCIATORS</b>	<b>OFF</b>	<b>rEu</b>
	<b>nor</b>	<b>FLASH</b>
<b>brn-n - PROBE BURN-OUT ACTION</b>	<b>00</b>	<b>OFF</b>

## 5.7 MODULE 7 - Serial Communications Parameters (7-5rL)

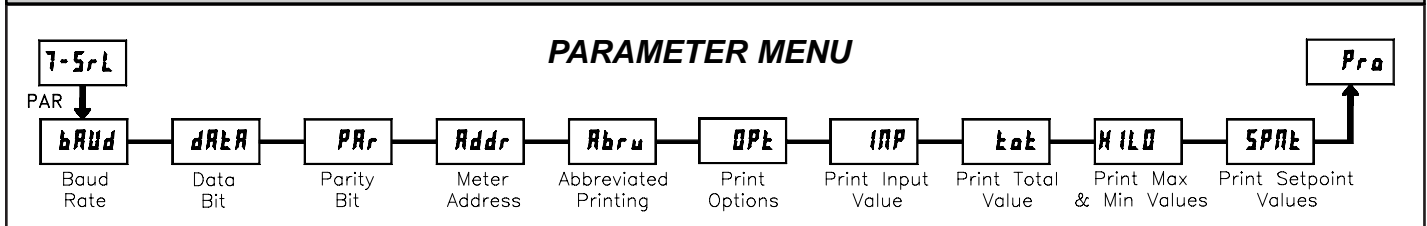

This module is for RS232 and RS485.

<b>brud - BAUD RATE</b>	<b>300</b>	<b>4800</b>
	<b>600</b>	<b>9600</b>
	<b>1200</b>	<b>19200</b>
	<b>2400</b>	
<b>dRtR - DATA BITS</b>	<b>7</b>	<b>8</b>

<b>PRr - PARITY BIT</b>	<b>Odd</b>	<b>00</b>
	<b>EVEN</b>	
<b>Rddr - METER ADDRESS</b>	<b>0 to 99</b>	
<b>Rbru - ABBREVIATED PRINTING</b>	<b>00</b>	<b>YES</b>
<b>OPt - PRINT OPTIONS</b>	<b>INP</b>	<b>HILO</b>
	<b>LoL</b>	<b>SPnL</b>

## 5.8 MODULE 8 - Analog Output Parameters (8-0ut)

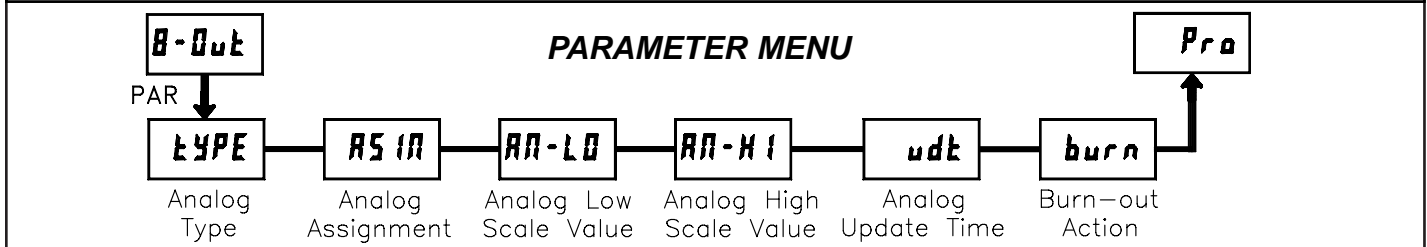

<b>tYPE - ANALOG TYPE</b>	<b>0-20</b>	<b>0-10</b>
	<b>4-20</b>	
<b>AS n - ANALOG ASSIGNMENT</b>	<b>INP</b>	<b>LO</b>
	<b>HI</b>	<b>LoL</b>

<b>AN-LO - ANALOG LOW SCALE VALUE</b>	<b>-19999 to 99999</b>	
<b>AN-HI - ANALOG HIGH SCALE VALUE</b>	<b>-19999 to 99999</b>	
<b>udt - ANALOG UPDATE TIME</b>	<b>00 to 100 sec.</b>	
<b>burn - PROBE BURN-OUT ACTION</b>	<b>HI</b>	<b>LO</b>

## 5.9 MODULE 9 - Factory Service Operations (9-FCS)

### PARAMETER MENU

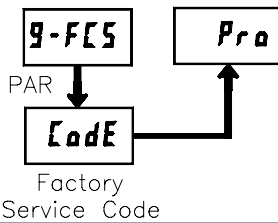

### CALIBRATION

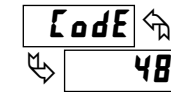

The meter has been fully calibrated at the factory. If the meter appears to be indicating incorrectly or inaccurately, refer to Troubleshooting before attempting to calibrate the meter. When recalibration is required (generally every 2 years), it should only be performed by qualified technicians using appropriate equipment.

Calibration may be aborted by disconnecting power to the meter before exiting Module 9. In this case, the existing calibration settings remain in effect.



**Warning:** Calibration of this meter requires precision instrumentation operated by qualified technicians. It is recommended that a calibration service calibrates the meter.

### INPUT CALIBRATION

Before selecting any of the calibration procedures, the input to the meter must be at 0 mV or 0 ohms. Allow a 30 minute warm up period. Set the digital filter in Module 1 to 1 second. The **no** and **PAR** can be chosen to exit calibration mode without any changes taking place.

#### 10 OHM RTD RANGE CALIBRATION

1. Set the Input Range Jumper to 10 ohm.
2. Use the arrow keys to display **Code 48** and press **PAR**. Then choose **r - 10** and press **PAR**.
3. At **0 r**, apply a direct short to input terminals 3, 4 and 5 using a three wire link. Wait 10 seconds, then press **PAR**.
4. At **15 r**, apply a precision resistance of 15 ohms (with an accuracy of 0.01% or better) using a three wire link, to input terminals 3, 4 and 5. Wait 10 seconds, then press **PAR**.
5. Connect the RTD, return to the Display Mode and verify the input reading (with 0 Display Offset) is correct. If not correct repeat calibration.

#### 100 OHM RTD RANGE CALIBRATION

1. Set the Input Range Jumper to 100 ohm.
2. Use the arrow keys to display **Code 48** and press **PAR**. Then choose **r - 100** and press **PAR**.
3. At **0 r**, apply a direct short to input terminals 3, 4 and 5 using a three wire link. Wait 10 seconds, then press **PAR**.
4. At **300 r**, apply a precision resistance of 300 ohms (with an accuracy of 0.01% or better) using a three wire link, to terminals 3, 4 and 5. Wait 10 seconds, press **PAR**.
5. Connect the RTD, return to the Display Mode and verify the input reading (with 0 Display Offset) is correct. If not correct repeat calibration.

#### THERMOCOUPLE RANGE CALIBRATION

1. Use the arrow keys to display **Code 48** and press **PAR**. Then choose **TE** and press **PAR**.
2. At **00 u**, apply a dead short or set calibrator to zero to input terminals 4 and 5. Wait 10 seconds, then press **PAR**.
3. At **500 u**, apply 50.000 mV input signal (with an accuracy of 0.01% or better) to input terminals 4 and 5. Wait 10 seconds, then press **PAR**.
4. Return to the Display Mode.
5. Continue with Ice Point Calibration.

### ICE POINT CALIBRATION

1. Remove all option cards or invalid results will occur.
2. The ambient temperature must be within 20°C to 30°C.
3. Connect a thermocouple (types T, E, J, K, or N only) with an accuracy of 1°C or better to the meter.
4. Verify the readout Display Offset is 0, Temperature Scale is °C, Display Resolution is 0.0, and the Input Range is set for the connected thermocouple.
5. Place the thermocouple in close thermal contact to a reference thermometer probe. (Use a reference thermometer with an accuracy of 0.25°C or better.) The two probes should be shielded from air movement and allowed sufficient time to equalize in temperature. (A calibration bath could be used in place of the thermometer.)
6. In the Normal Display mode, compare the readouts.
7. If a difference exists then continue with the calibration.
8. Enter Module 9, use the arrow keys to display **Code 48** and press **PAR**. Then choose **ICE** and press **PAR**.
9. Calculate a new Ice Point value using: existing Ice Point value + (reference temperature - Display Mode reading). All values are based on °C.
10. Enter the new Ice Point value.
11. Return to the Display Mode and verify the input reading (with 0 Display Offset) is correct. If not correct repeat steps 8 through 10.

### Analog Output Card Calibration

Before starting, verify that the precision voltmeter (voltage output) or current meter (current output) is connected and ready. Perform the following procedure:

1. Use the arrow keys to display **Code 48** and press **PAR**.
2. Use the arrow keys to choose **OUT** and press **PAR**.
3. Using the chart below, step through the five selections to be calibrated. At each prompt, use the PAX arrow keys to adjust the external meter display to match the selection being calibrated. When the external reading matches, or if this range is not being calibrated, press **PAR**.

SELECTION	EXTERNAL METER	ACTION
000	0.00	Adjust if necessary, press <b>PAR</b>
400	4.00	Adjust if necessary, press <b>PAR</b>
2000	20.00	Adjust if necessary, press <b>PAR</b>
00u	0.00	Adjust if necessary, press <b>PAR</b>
100u	10.00	Adjust if necessary, press <b>PAR</b>

4. When **00** appears remove the external meters and press **PAR** twice.

### RESTORE FACTORY DEFAULTS

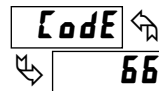

Use the arrow keys to display **Code 66** and press **PAR**. The meter will display **RESET** and then return to **Code 50**. Press **DSP** key to return to Display Mode. This will overwrite all user settings with the factory settings.

## TROUBLESHOOTING

PROBLEM	REMEDIES
NO DISPLAY	CHECK: Power level, power connections
PROGRAM LOCKED-OUT	CHECK: Active (lock-out) user input ENTER: Security code requested
MAX, MIN, TOT LOCKED-OUT	CHECK: Module 3 programming
INCORRECT INPUT DISPLAY VALUE	CHECK: Module 1 programming, RTD Input Jumper position, input connections, input signal level, Display Offset is zero, DSP is on Input Display PERFORM: Calibration (If the above does not correct the problem.)
"LOL" in DISPLAY (SIGNAL LOW)	CHECK: Module 1 programming, RTD Input Jumper position, input connections, input signal level
"LUL" in DISPLAY (SIGNAL HIGH)	CHECK: Module 1 programming, RTD Input Jumper position, input connections, input signal level
JITTERY DISPLAY	INCREASE: Module 1 filtering, rounding, input range CHECK: Wiring is per EMC installation guidelines
MODULES or PARAMETERS NOT ACCESSIBLE	CHECK: Corresponding plug-in card installation
ERROR CODE (Err 1-4)	PRESS: Reset KEY (If can not clear contact factory.)

For further assistance, contact technical support at the appropriate company numbers listed.

# PARAMETER VALUE CHART

## PAXT RTD and Thermocouple meter

Programmer \_\_\_\_\_

Date \_\_\_\_\_

Meter# \_\_\_\_\_

Security Code \_\_\_\_\_

### 1- INP Signal Input Parameters

DISPLAY	PARAMETER	FACTORY SETTING	USER SETTING
TYPE	INPUT TYPE	tc-d	_____
SCALE	TEMPERATURE SCALE	of	_____
DECPt	DISPLAY RESOLUTION	0	_____
round	DISPLAY ROUNDING INCREMENT	1	_____
OFFSt	DISPLAY OFFSET	0	_____
Filter	FILTER SETTING	10	_____
band	FILTER ENABLE BAND	10	_____
ICE	ICE POINT SLOPE	0.00	_____
PtS	SCALING POINTS	2	_____
INP 1	INPUT VALUE 1	0.000	_____
dSP 1	DISPLAY VALUE 1	0	_____
INP 2	INPUT VALUE 2	1.000	_____
dSP 2	DISPLAY VALUE 2	1.000	_____
INP 3	INPUT VALUE 3	0.000	_____
dSP 3	DISPLAY VALUE 3	0	_____
INP 4	INPUT VALUE 4	0.000	_____
dSP 4	DISPLAY VALUE 4	0	_____
INP 5	INPUT VALUE 5	0.000	_____
dSP 5	DISPLAY VALUE 5	0	_____
INP 6	INPUT VALUE 6	0.000	_____
dSP 6	DISPLAY VALUE 6	0	_____
INP 7	INPUT VALUE 7	0.000	_____
dSP 7	DISPLAY VALUE 7	0	_____
INP 8	INPUT VALUE 8	0.000	_____
dSP 8	DISPLAY VALUE 8	0	_____
INP 9	INPUT VALUE 9	0.000	_____
dSP 9	DISPLAY VALUE 9	0	_____
INP 10	INPUT VALUE 10	0.000	_____
dSP 10	DISPLAY VALUE 10	0	_____
INP 11	INPUT VALUE 11	0.000	_____
dSP 11	DISPLAY VALUE 11	0	_____
INP 12	INPUT VALUE 12	0.000	_____
dSP 12	DISPLAY VALUE 12	0	_____
INP 13	INPUT VALUE 13	0.000	_____
dSP 13	DISPLAY VALUE 13	0	_____
INP 14	INPUT VALUE 14	0.000	_____
dSP 14	DISPLAY VALUE 14	0	_____
INP 15	INPUT VALUE 15	0.000	_____
dSP 15	DISPLAY VALUE 15	0	_____
INP 16	INPUT VALUE 16	0.000	_____
dSP 16	DISPLAY VALUE 16	0	_____

### 3-LOC Display and Program Lockout Parameters

DISPLAY	PARAMETER	FACTORY SETTING	USER SETTING
H1	MAX DISPLAY LOCKOUT	rEd	_____
L0	MIN DISPLAY LOCKOUT	rEd	_____
t0t	TOTAL DISPLAY LOCKOUT	rEd	_____
SP-1	SETPOINT 1 ACCESS	LOC	_____
SP-2	SETPOINT 2 ACCESS	LOC	_____
SP-3	SETPOINT 3 ACCESS	LOC	_____
SP-4	SETPOINT 4 ACCESS	LOC	_____
Code	SECURITY CODE	0	_____

### 4-SEC Secondary Function Parameters

DISPLAY	PARAMETER	FACTORY SETTING	USER SETTING
H1-t	MAX CAPTURE DELAY TIME	0.0	_____
L0-t	MIN CAPTURE DELAY TIME	0.0	_____
dSP-t	DISPLAY UPDATE TIME	2	_____
b-L t	UNITS LABEL BACKLIGHT	0n	_____
ICE	ICE POINT COMPENSATION	0n	_____

### 5-t0t Totalizer (Integrator) Parameters

DISPLAY	PARAMETER	FACTORY SETTING	USER SETTING
DECPt	TOTALIZER DECIMAL POINT	0	_____
tBASE	TOTALIZER TIME BASE	hour	_____
SCALE	TOTALIZER SCALE FACTOR	1.000	_____
Locut	TOTALIZER LOW CUT VALUE	-19999	_____
P-UP	TOTALIZER POWER-UP RESET	no	_____

### 7-5rL Serial Communication Parameters

DISPLAY	PARAMETER	FACTORY SETTING	USER SETTING
bAUD	BAUD RATE	9600	_____
dAR	DATA BIT	7	_____
PAR	PARITY BIT	0dd	_____
Raddr	METER ADDRESS	0	_____
Abbr	ABBREVIATED PRINTING	YES	_____
INP	PRINT INPUT VALUE	YES	_____
t0t	PRINT TOTAL VALUE	YES	_____
HIL0	PRINT MAX & MIN VALUES	YES	_____
SPnt	PRINT SETPOINT VALUES	no	_____

### 2-FNC User Input and Function Key Parameters

DISPLAY	PARAMETER	FACTORY SETTING	USER SETTING
USR-1	USER INPUT 1	no	_____
USR-2	USER INPUT 2	no	_____
USR-3	USER INPUT 3	no	_____
F1	FUNCTION KEY 1	no	_____
F2	FUNCTION KEY 2	no	_____
rSt	RESET KEY	no	_____
Sc-F1	2nd FUNCTION KEY 1	no	_____
Sc-F2	2nd FUNCTION KEY 2	no	_____

### 8-OUT Analog Output Parameters

DISPLAY	PARAMETER	FACTORY SETTING	USER SETTING
TYPE	ANALOG TYPE	4-20	_____
AS IN	ANALOG ASSIGNMENT	INP	_____
AN-L0	ANALOG LOW SCALE VALUE	0	_____
AN-H1	ANALOG HIGH SCALE VALUE	1000	_____
udt	ANALOG UPDATE TIME	0.0	_____
burn	PROBE BURN-OUT ACTION	L0	_____

### 6-SPt Setpoint (Alarm) Parameters

DISPLAY	PARAMETER	SP-1		SP-2		SP-3		SP-4	
		FACTORY SETTING	USER SETTING	FACTORY SETTING	USER SETTING	FACTORY SETTING	USER SETTING	FACTORY SETTING	USER SETTING
Act-n	SETPOINT ACTION	OFF	_____	OFF	_____	OFF	_____	OFF	_____
SP-n	SETPOINT VALUE (main)	100	_____	200	_____	300	_____	400	_____
	SETPOINT VALUE (alternate)*	100	_____	200	_____	300	_____	400	_____
HYS-n	SETPOINT HYSTERESIS	2	_____	2	_____	2	_____	2	_____
t0n-n	ON TIME DELAY	0.0	_____	0.0	_____	0.0	_____	0.0	_____
t0f-n	OFF TIME DELAY	0.0	_____	0.0	_____	0.0	_____	0.0	_____
out-n	OUTPUT LOGIC	nor	_____	nor	_____	nor	_____	nor	_____
rSt-n	RESET ACTION	RUto	_____	RUto	_____	RUto	_____	RUto	_____
Stb-n	STANDBY OPERATION	no	_____	no	_____	no	_____	no	_____
L t-n	SETPOINT ANNUNCIATORS	nor	_____	nor	_____	nor	_____	nor	_____
brn-n	PROBE BURN-OUT ACTION	OFF	_____	OFF	_____	OFF	_____	OFF	_____

\* Select alternate list to program these values.

