

MODEL EPAX- 6 DIGIT EXTRA LARGE PAX DISPLAY FOR DIGITAL INPUTS



- LARGE LED DISPLAY READABLE TO 180 FEET
- VARIOUS DIGITAL INPUT MODULES;
COUNT AND RATE INPUT
CLOCK/TIMER
SERIAL SLAVE
- ALARMS, ANALOG OUTPUT, AND COMMUNICATION
- PROGRAMMABLE USER INPUTS
- UNIVERSAL AC POWERED (85 to 250 VAC)
- PC SOFTWARE FOR METER CONFIGURATION
- NEMA 4/IP65

GENERAL DESCRIPTION

The EPAX Display is a versatile display that can increase productivity by offering the plant floor or production area a large visual display of their current status. Whether your measurement is rate, count, or time, the EPAX can satisfy your requirement. The EPAX displays accept various digital inputs through the use of input modules (MPAX) which allow the unit to adapt to most any application. The MPAX Modules offer the same features as our highly successful PAX Series Panel Meters. Additional plug-in option cards can add alarms, analog output, and communication/bus capabilities, making the EPAX a truly Intelligent Panel Meter.

SAFETY SUMMARY

All safety regulations, local codes and instructions that appear in this and corresponding literature, or on equipment, must be observed to ensure personal safety and to prevent damage to either the instrument or equipment connected to it. If equipment is used in a manner not specified by the manufacturer, the protection provided by the equipment may be impaired.



The protective conductor terminal is bonded to conductive parts of the equipment for safety purposes and must be connected to an external protective earthing system.

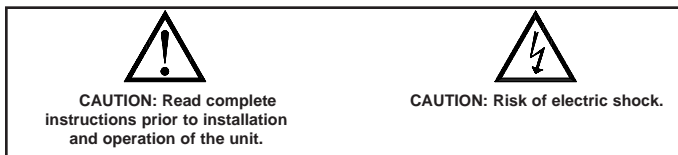

SPECIFICATIONS

Additional specifications, wiring, programming, and information for the individual MPAX models are contained in the corresponding standard PAX literature. This PAX literature is shipped with the ordered MPAX model.

1. **DISPLAY:** 4" (101 mm) Red LED
6-Digit (EPAX0600): (-99999 to 999999)
2. **POWER REQUIREMENTS:**
AC MPAX Modules: 85 to 250 VAC, 50/60 Hz, 18 VA
EPAX Display: 85 to 250 VAC, 50/60 Hz, 5 VA
3. **INPUT:** Accepts digital input modules, see "Selecting Your Display Components and Option Cards."
4. **ANNUNCIATORS:**

Display Indication: Three vertical dots on the left side of the unit identify the displays for the following modules:

	COUNT/RATE	CLOCK
TOP	Display A	Timer
MIDDLE	Display B	Count
BOTTOM	Display C	Date

Setpoint Indication: Four vertical dots on the right side of the unit identify the setpoint "ON" condition, with SP 1 being the top position through SP 4 at the bottom.

5. **EPAX Programming:** The unit is a large display, designed to be remotely mounted. Therefore, the unit does not have a programming keypad. Unit programming should be accomplished by one of the following methods:

Rear Terminal Block: External switches can be wired via the terminal block to allow unit programming. A minimum of 3 switches would be required.

Optional Programming Remote (EPAXPGM0): This option provides a 10 foot interconnecting cable and programming box. The Programming Remote contains buttons similar to the PAX, allowing easy programming of the EPAX display.

Optional Serial Programming: Like all PAX units, you can purchase an RS232 or RS485 Comms Card and program the unit via RLCPro, a Windows® based software program.

DIMENSIONS In inches (mm)

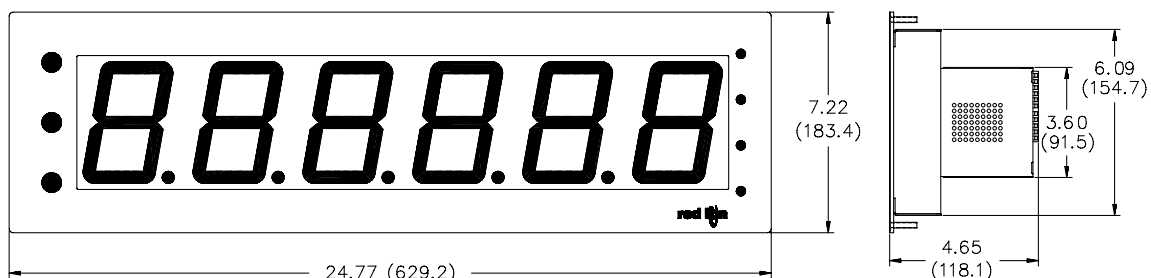

6. CERTIFICATIONS AND COMPLIANCES:

SAFETY

- Type 4 Enclosure rating (Face Only), UL50
- IEC 1010-1, EN 61010-1: Safety requirements for electrical equipment for measurement, control, and laboratory use, Part 1.
- IP65 Enclosure rating (Face only), IEC 529

ELECTROMAGNETIC COMPATIBILITY

EMC specifications determined by the MPAX module.

7. ENVIRONMENTAL CONDITIONS:

- Operating Temperature Range: Determined by the MPAX module
- Storage Temperature Range: -40 to 60°C
- Operating and Storage Humidity: 0 to 85% max. RH (non-condensing)
- Altitude: Up to 2000 meters

8. MOUNTING REQUIREMENTS:

- Max. panel thickness is 0.375" (9.5 mm)
- Min. panel thickness for NEMA 4/IP65 sealing is 0.060" (1.52 mm)

9. MODULE INSTALLATION:

24-pin shrouded connector on EPAX engages connector on MPAX module upon installation. Shroud ensures proper alignment by providing a lead-in for the module connector.

10. CONNECTIONS: Wiring connections are made to the EPAX terminal block and MPAX module via high compression cage-clamp terminal blocks. Wiring instructions are provided with the MPAX module.

- Wire Strip Length: 0.3" (7.5 mm)
- Wire Gauge Capacity: One 14 AWG (2.55 mm) solid, two 18 AWG (1.02 mm), four 20 AWG (0.61 mm)



CAUTION: DISCONNECT ALL POWER BEFORE INSTALLING OR REMOVING MODULE

11. CONSTRUCTION: Aluminum front panel, enclosure, and rear cover with textured black polyurethane paint for scratch and corrosion resistance protection. Sealed front panel meets NEMA 4/IP65 specifications for indoor use when properly installed. Installation Category II, Pollution Degree 2. Panel gasket and keps nuts included.

12. WEIGHT: 5 lbs (2.25 kg) (*less module*)

About the MPAX Input Modules

The MPAX Module serves as the input to the EPAX Display. There are several different modules to cover a variety of inputs. The MPAX module provides input scaling which allows the EPAX to display most any engineering unit. Once the MPAX is inserted into the EPAX, the unit has the same functions and capabilities of our PAX Series Intelligent Panel Meters. A full set of PAX programming instructions will be included with the MPAX module.

Selecting Your Display Components and Option Cards

To build a complete display unit, you will need an EPAX and an MPAX Input Module. The EPAX is only a display and will not operate without an MPAX module. Please use the following chart to identify the appropriate MPAX module and EPAX Display that will satisfy your application.

SIGNAL TYPE	MPAX MODULES*	EPAX DISPLAYS	OPTIONAL PLUG-IN CARD COMPATABILITY			
	85-250 VAC		SETPOINT	COMMS	ANALOG	REAL-TIME CLOCK
Count/Rate/Serial Slave	MPAXI000	EPAX0600	YES	YES	YES	-
Count	MPAXC000	EPAX0600	YES	-	-	-
Rate	MPAXR000	EPAX0600	YES	-	-	-
Clock/Timer	MPAXCK00	EPAX0600	YES	YES	-	YES

* For detailed module and plug-in card specifications, see corresponding PAX literature. (i.e. For MPAXI specifications, see the PAXI literature)

OPTIONAL PLUG-IN CARDS AND ACCESSORIES



WARNING: Disconnect all power to the unit before installing Plug-in cards.

Adding Option Cards

The PAX and MPAX series meters can be fitted with up to three optional plug-in cards. The details for each plug-in card can be reviewed in the specification section of the PAX Bulletin. Only one card from each function type can be installed at one time. The function types include Setpoint Alarms (PAXCDS), Communications (PAXCDC), and Analog Output (PAXCDL). The PAXCK Timer can function as a Real-Time Clock with the addition of the Real-Time Clock Card (PAXRTC). The plug-in cards can be installed initially or at a later date.

SETPOINT ALARMS PLUG-IN CARDS (PAXCDS)

The PAX and MPAX series have 4 available setpoint alarm output plug-in cards. Only one of these cards can be installed at a time. (Logic state of the outputs can be reversed in the programming.) These plug-in cards include:

- PAXCDS10 - Dual Relay, FORM-C, Normally open & closed
- PAXCDS20 - Quad Relay, FORM-A, Normally open only
- PAXCDS30 - Isolated quad sinking NPN open collector
- PAXCDS40 - Isolated quad sourcing PNP open collector

COMMUNICATION PLUG-IN CARDS (PAXCDC)

A variety of communication protocols are available for the PAX and MPAX series. Only one of these cards can be installed at a time. When programming the unit via RLCPro, a Windows® based program, the RS232 or RS485 Cards must be used.

- PAXCDC10 - RS485 Serial
- PAXCDC20 - RS232 Serial
- PAXCDC30 - DeviceNet
- PAXCDC40 - Modbus

ANALOG OUTPUT PLUG-IN CARD (PAXCDL)

Either a 0(4)-20 mA or 0-10 V retransmitted linear DC output is available from the analog output plug-in card. The programmable output low and high scaling can be based on various display values. Reverse slopes output is possible by reversing the scaling point positions.

PAXCDL10 - Retransmitted Analog Output Card

REAL-TIME CLOCK PLUG-IN CARD (PAXRTC)

The Real-Time Clock plug-in card will only operate with the PAXCK or MPAXCK series meters. It includes a lithium coin-cell battery, that maintains the time and date when power is removed.

PAXRTC00 - Real-Time Clock Card

PROGRAMMING SOFTWARE

The SFPAX is a Windows® based program that allows configuration of the PAX meter from a PC. Using the SFPAX makes it easier to program the PAX meter and allows saving the PAX program in a PC file for future use. On-line help is available within the software. A PAX serial plug-in card is required to program the meter using the software.

1.0 ASSEMBLING THE DISPLAY



CAUTION: The MPAX main circuit board and the option cards contain static sensitive components. Before handling the module or the cards, discharge static charges from your body by touching a grounded bare metal object. Handle the module by the rear plastic cover only, and the option cards by the board edges. Dirt, oil or other contaminants that contact the circuit boards or components can adversely affect circuit operation.



WARNING: Exposed line voltage exists on the MPAX main circuit board and the option cards. **DO NOT** apply power to the module OR load circuits until the module is properly installed in the EPAX case.



NOTE: All module and option card labels must be installed as shown for safety purposes.

Prior to installing the EPAX Display, it is recommended that the MPAX and any option cards be assembled first. This will allow you the opportunity to insure all the boards are fitted properly into their connectors.

Installing the Option Cards

If your application requires option cards, they should be installed into the MPAX before it is installed into the EPAX Display. Refer to the literature enclosed with the option cards for installation instruction.

Installing the MPAX

To install the MPAX Module, align the module with the opening in the EPAX case, as illustrated. The module must be oriented as shown, with terminal #1 toward the top of the EPAX case. Carefully slide the module into the EPAX case. The EPAX and MPAX connectors will begin to engage about 1/4" from the bottom. At this point, apply a small amount of pressure to the rear of the MPAX module to fully engage the connection. Be sure the module fully snaps into the slots at the rear of the EPAX case. The MPAX module holder can be removed with a 1/4" nut driver to make inserting the MPAX easier. The display is ready for installation.

Installing the Labels

Each option card and the MPAX are shipped with a connection label. These labels must be applied to the rear of the EPAX in the positions shown in the drawing.

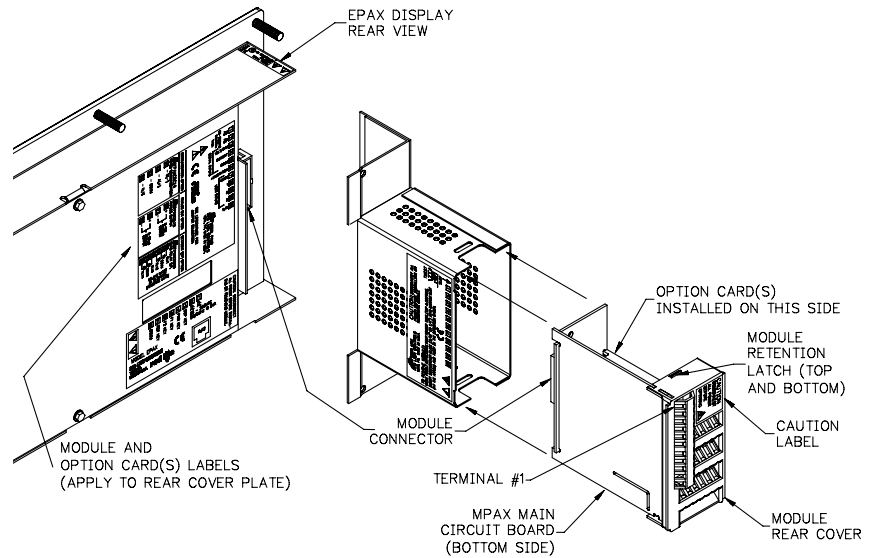

Figure 1, Installing an MPAX Module and Option Cards

Removing The MPAX Module

To remove the MPAX Module from the EPAX Display, first remove all power and load circuits. Then insert a flat screwdriver blade (3/16" or 1/4") into the narrow slot between the EPAX rear cover plate and the module's plastic cover as illustrated in Figure 2. Twist the screwdriver in the direction shown to disengage the internal connectors while firmly squeezing and pulling back on the rear finger tabs (top and bottom). Carefully slide the module out of the EPAX case, keeping it properly aligned with the case opening.

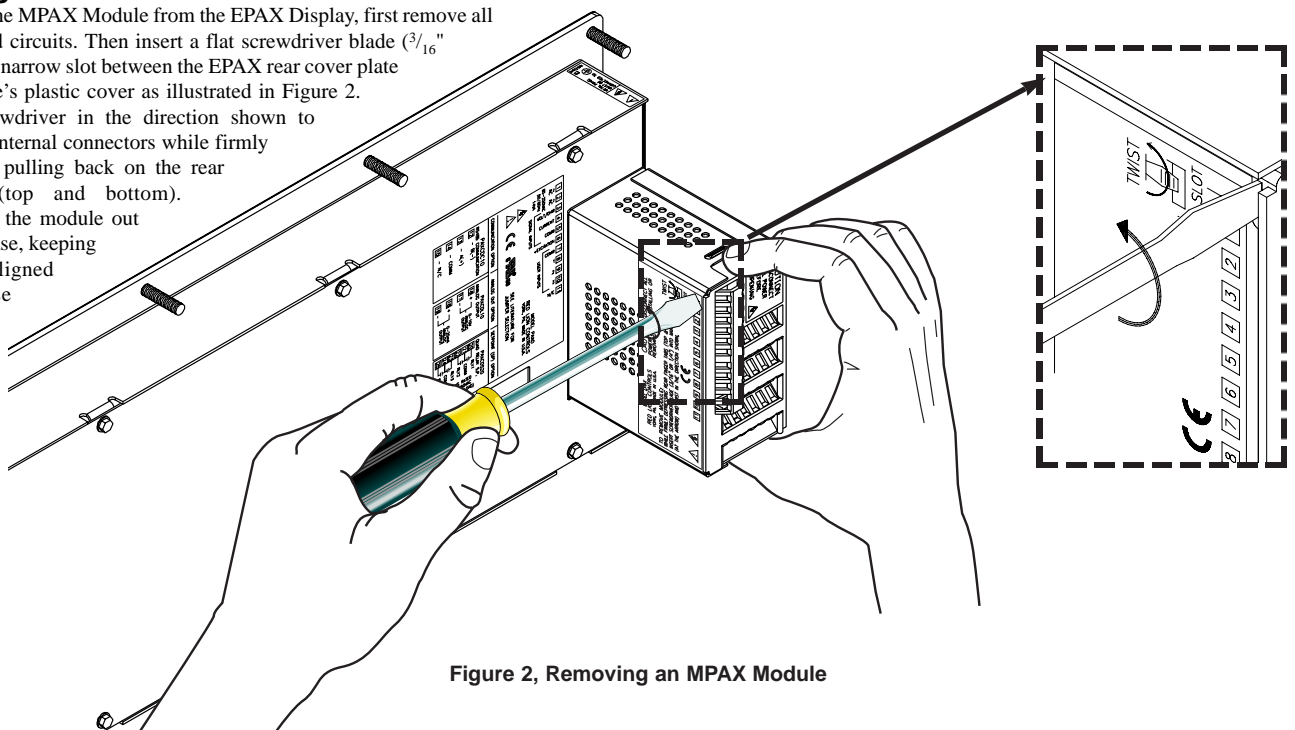

Figure 2, Removing an MPAX Module

2.0 INSTALLING THE DISPLAY

EPAX DISPLAY INSTALLATION

The EPAX display is intended to be mounted into a panel or enclosure. The display is provided with a gasket to provide a water-tight seal. The recommended minimum panel thickness for NEMA 4/IP65 sealing is 0.060" (1.57 mm).

For panel mounting, prepare the panel cut-out to the dimensions shown in Figure 3. The supplied template may be used to mark the cut-out and hole locations on the panel. After the panel cut-out has been deburred, slide the panel gasket over the rear of the display and onto the mounting studs. Insert the display into the panel cut-out as illustrated in Figure 4. Install 14 # 10-32 keps nuts (supplied) and tighten evenly for uniform gasket compression. Do not over-tighten the nuts.

By using additional mounting accessories, the EPAX can be surface-wall mounted, suspended, or bottom mounted. Separate installation instructions are provided with the mounting accessories.

DIMENSIONS In inches (mm)

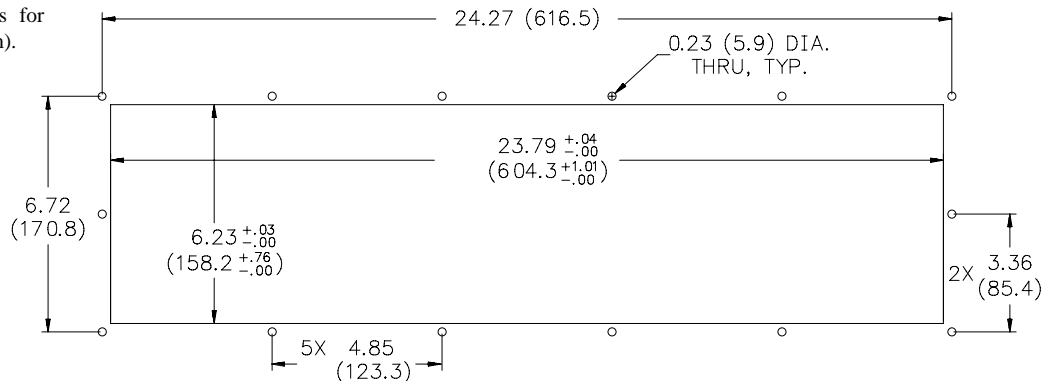

Figure 3, Panel Cut-out for the EPAX

Environment And Cleaning

The display should be installed in a location that does not exceed the maximum operating temperature and provides good air circulation. Placing the system near devices that generate excessive heat should be avoided.

The bezel should be cleaned only with a soft cloth and neutral soap product. Do NOT use solvents. Continuous exposure to direct sunlight may accelerate the aging process of the bezel.

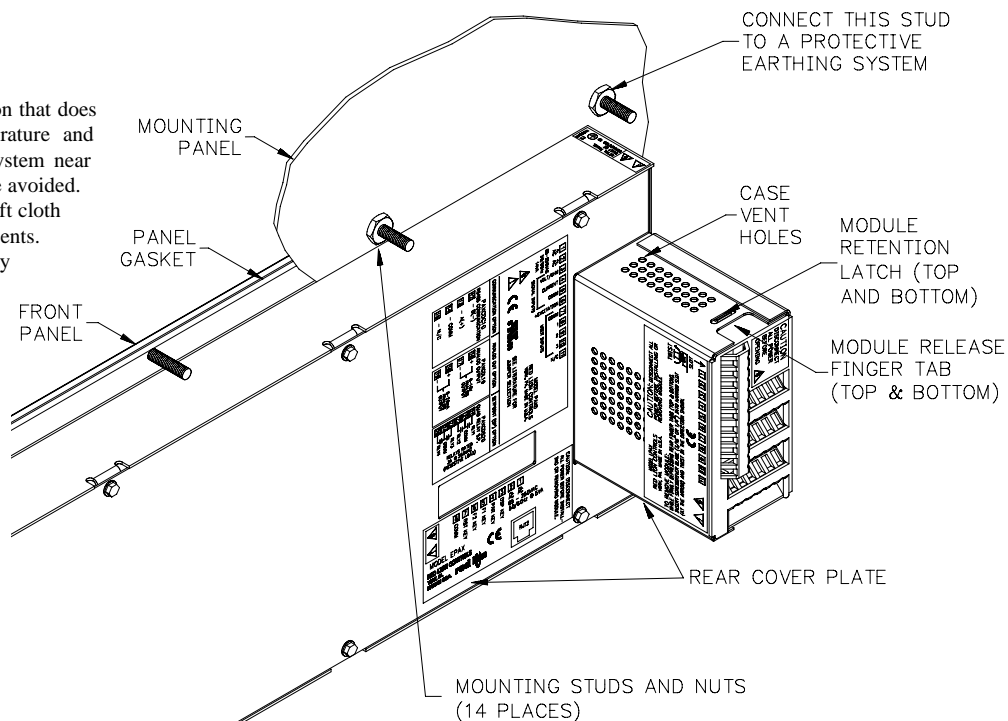

Figure 4, Installing The EPAX Into A Panel

3.0 WIRING AND PROGRAMMING THE DISPLAY

Once assembled, the EPAX and MPAX have all the same functions and capabilities of our PAX Series Intelligent Panel Meters. Therefore, you will find the appropriate PAX information packed with the MPAX Module. Simply follow the instructions to wire and program the display for your application.

Note: Both the EPAX and the MPAX module require power. It is recommended to connect the primary AC power to the EPAX terminal block, then jumper to the MPAX module.

EPAX PROGRAMMING

The unit is a large display, designed to be remotely mounted. Therefore, the unit does not have a programming keypad. Unit programming must be accomplished by one of the following three methods:

Optional Programming Remote (EPAXPGM0)

This optional programming remote plugs into the EPAX through an RJ12 connector and a 10 foot cable. The buttons on the programming box function the same as the PAX unit. Simply program the EPAX exactly as the PAX instructions indicate. The programming box can be left connected to the EPAX for future programming changes or can be disconnected and used to program additional EPAX units.



RJ12 CONNECTOR ON BOTTOM OF UNIT

RJ12 FEMALE	
PIN	NAME
1	DSP KEY
2	PAR KEY
3	F1 KEY
4	F2 KEY
5	RST KEY
6	COMM

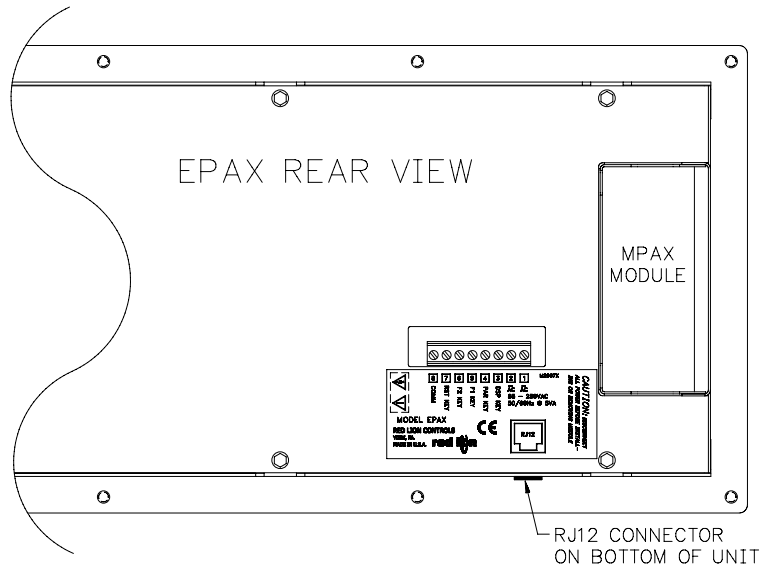
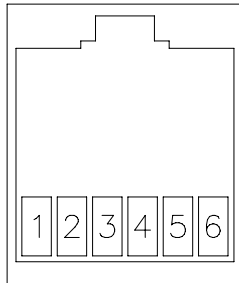

Rear Terminal Block

External normally open switches can be wired via the terminal block to allow unit programming. A minimum of 3 switches would be required. Each external switch must be wired between the key and the common terminal.

EPAX TERMINAL BLOCK

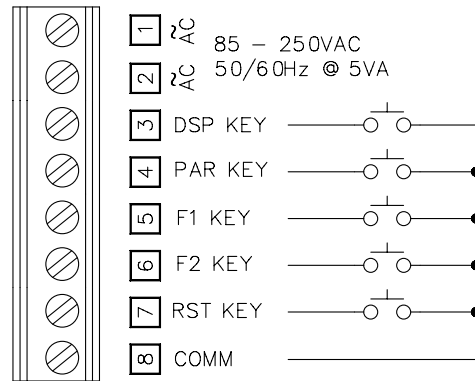

Optional Serial Programming

Like all PAX units, you can purchase an RS232 or RS485 Comms Card and program the unit via RLCPro, a Windows® based software program.

NEMA 4/IP65 LARGE DISPLAY ENCLOSURE & SHROUD FOR EPAX



Picture includes the EPAX, Nema Enclosure, and Shroud

- LIGHT-WEIGHT ALUMINUM CONSTRUCTION
- COMPLETELY SEALED FOR WASH-DOWN
- MOUNTING CHANNELS FOR VERSATILE INSTALLATION

DESCRIPTION

The NEMA 4/IP65 Large Display Enclosure is designed to protect the EPAX from dust and hose directed water, when properly installed. This light-weight all aluminum unit utilizes welded seams and neoprene gaskets to meet NEMA 4/IP65 requirements. A textured, polyurethane coating protects against corrosion and is scratch resistant. Figure 1 below shows the overall dimensions of the Enclosure. The Display Enclosure with Mounting Channels weighs 9 pounds (4.1 Kg).

DIMENSIONS In inches (mm)

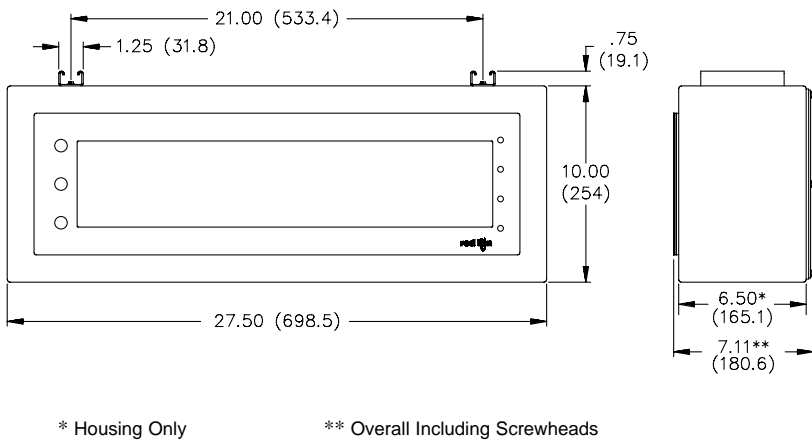

Figure 1

MOUNTING

Provided with the enclosure are two 1/4-20 UNC x 1" hex bolts, two 1/4-20 UNC "strut nuts", and two 1/4" washers. The "strut nuts" can be installed anywhere in the channel by inserting them, spring side down, into the channels, then rotating them 90 degrees clockwise until the notches engage with the lips of the channel. The bolts and washers provided allow mounting to surfaces 1/4" to 1/2" thick (6.4 to 12.7 mm). Use longer bolts for mounting to thicker surfaces. Bolts fabricated from materials other than steel are not recommended.

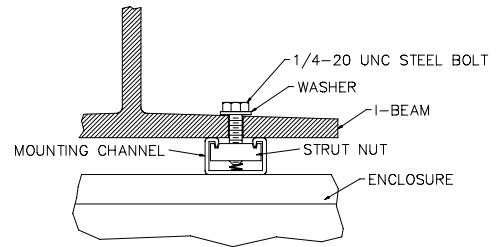
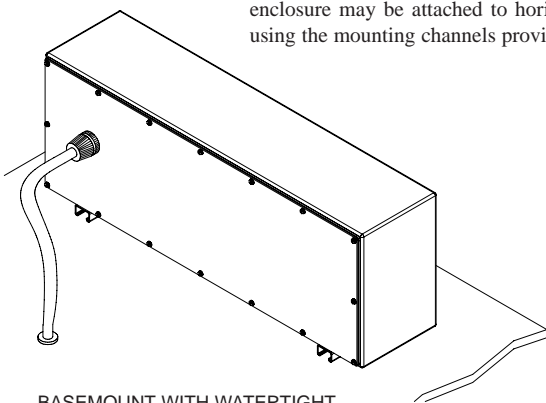

Figure 3

TYPICAL INSTALLATIONS FOR NEMA 4/IP65 ENCLOSURE

Removing the rear panel of the enclosure allows access to the Display for service. Either the rear panel or housing may be drilled to accept sealed conduit fittings, liquid-tight cable fittings or other types of wiring connectors. The enclosure may be attached to horizontal surfaces located above or below it, using the mounting channels provided.



BASEMOUNT WITH WATERTIGHT CABLE CONNECTOR ENTERING THROUGH REAR PANEL.

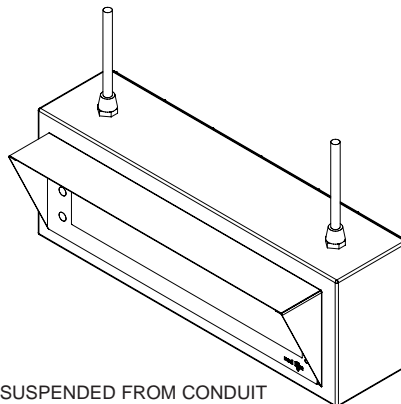

SUSPENDED FROM CONDUIT WITH SEALED FITTINGS. (SHOWN WITH SHROUD).

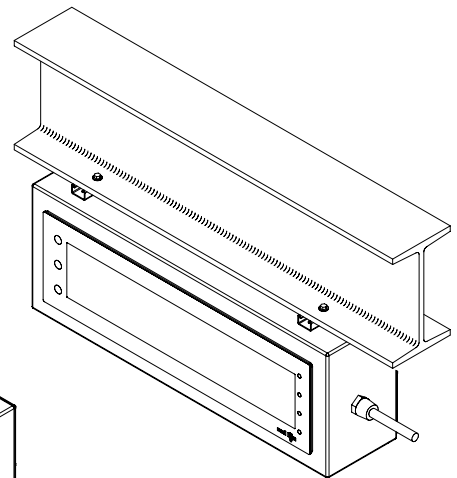

BEAM MOUNT WITH SEALED CONDUIT ENTERING FROM RIGHT SIDE.

Figure 2

ASSEMBLY AND INSTALLATION PROCEDURE

1. Install the two mounting channels on the enclosure housing using the four #8-32 screws provided and then insert the strut nuts (*provided*). Invert enclosure if base mounting.
2. If the wiring is to be routed through the housing, make sure that the mounting channels are oriented properly before drilling, so the Display will be readable. Wiring is generally brought into the right side of the housing or rear panel, closest to the terminals of the MPAX module. Drill the proper size hole in the housing or rear panel for the wiring connector or sealed conduit fitting and attach the fitting(s).
3. Before installing the Display into the housing, be sure that the mounting channels are oriented properly for the type of installation planned. Place the gasket that is supplied with the Display over the studs extending from the front panel of the display.
4. If using the shroud, refer to the Shroud Installation Procedure. Place the Display with gasket through the holes in the housing as shown at right. Working back and forth across the stud pattern, install the #10-32 keps nuts supplied with the Display on the studs. Tighten firmly.
5. Mount the housing, using the strut nuts and steel 1/4-20 UNC bolts and washers, as shown in figure 4.
6. Connect the wires to the Display per the instructions included with the personality board.
7. Remove the center section of the rear panel gasket. Apply the gasket to the rear panel of the enclosure by inserting the #8-32 screws through the panel and into the holes in the gasket. Position the panel on the housing, start all of the screws, then firmly tighten them in a pattern working back and forth across the rear panel.

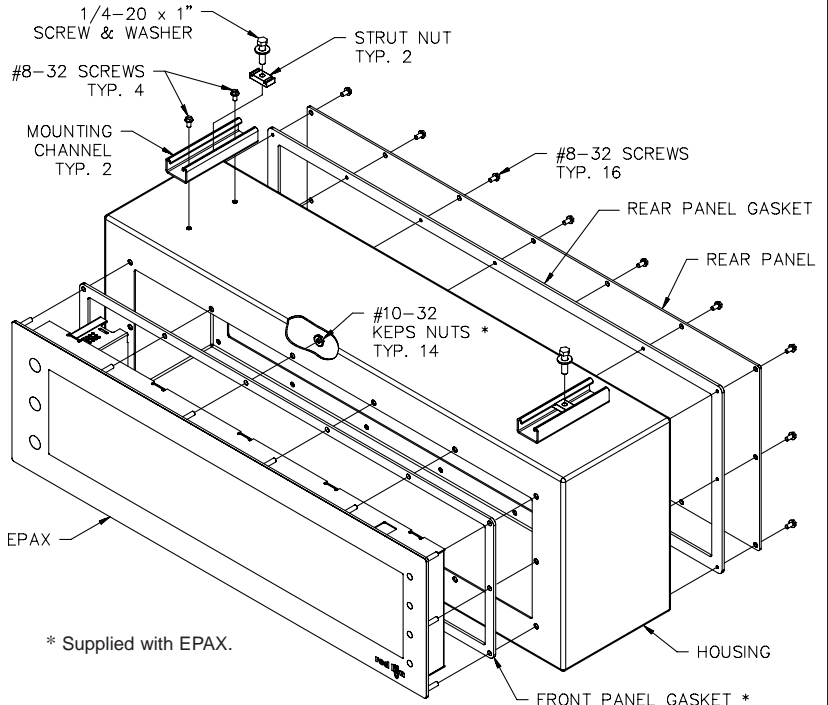

Figure 4

DIMENSIONS FOR THE EPAX DISPLAY SHROUD

The optional EPAX Display Shroud enhances the readability of the Displays that are installed in areas with high intensity overhead light sources. The Shroud can be used with the EPAX Display in any installation, (panel mount, NEMA 4/IP65 Enclosure, or Universal Mounting Bracket). When properly assembled, the Shroud will not affect the integrity of a NEMA 4/IP65 installation. The Shroud weighs 1.0 pounds (0.45 Kg).

DIMENSIONS In inches (mm)

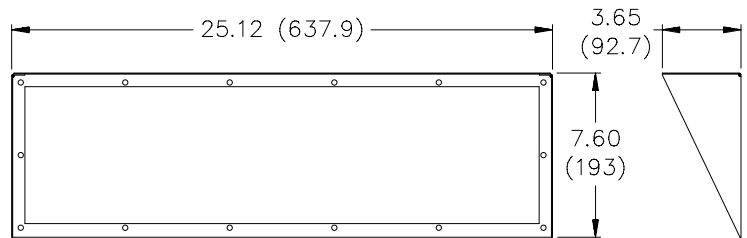

Figure 5

SHROUD INSTALLATION PROCEDURE

Installing The Shroud On An EPAX Display In A NEMA 4/IP65 Enclosure Or Panel

1. Place a gasket over the studs extending from the rear of the front panel of the Display.
2. Orient the shroud as shown in Figure 6, and place it over the display. The studs of the display should now be protruding through the rear of the shroud.
3. Place the other gasket over the studs.
4. Install the unit into the panel or enclosure using the #10-32 keps nuts that are supplied with the Display. Tighten the nuts firmly.

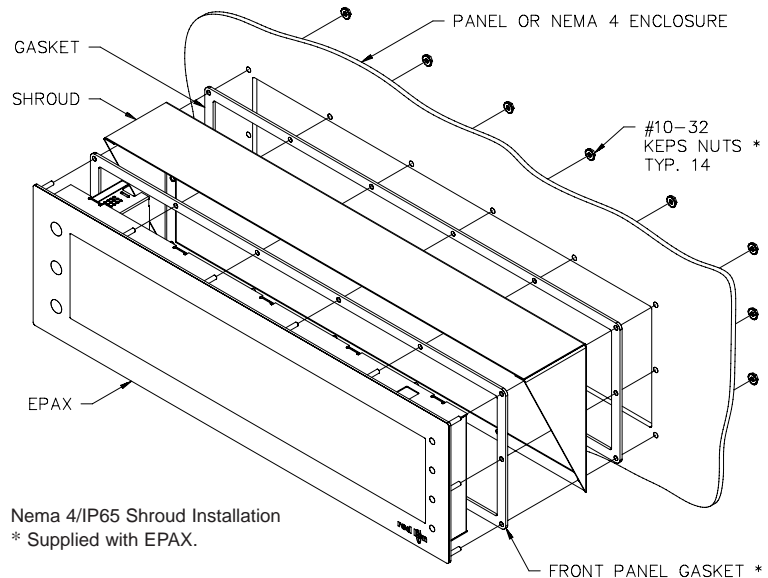

Figure 6

ORDERING INFORMATION

TYPE	MODEL NO.	DESCRIPTION	PART NUMBERS
Display	EPAX	6-Digit Extra Large Display for Digital MPAX Modules	EPAX0600
Digital Input Module	MPAX	Count/Rate Indicator Module, AC Powered	MPAXI000
		Count Indicator Module, AC Powered	MPAXC000
		Rate Indicator Module, AC Powered	MPAXR000
		Clock/Timer Module, AC Powered	MPAXCK00
Optional Plug-In Cards	PAXCDS	Dual Setpoint Relay Output Card	PAXCDS10
		Quad Setpoint Relay Output Card	PAXCDS20
		Quad Setpoint Sinking Open Collector Output Card	PAXCDS30
		Quad Setpoint Sourcing Open Collector Output Card	PAXCDS40
	PAXCDC*	RS485 Serial Communications Card	PAXCDC10
		RS232 Serial Communications Card	PAXCDC20
		DeviceNet Communications Card	PAXCDC30
		MODBUS Communications Card	PAXCDC40
		PROFIBUS-DP Communications Card	PAXCDC50
	PAXCDL*	Analog Output Card	PAXCDL10
	PAXRTC*	Real Time Clock Card	PAXRTC00
Accessories	PGM	Programming Remote for EPAX with 10 foot cable	EPAXPGM0
	SFPAX**	PC Configuration Software for Windows 95/98 (3.5" disk)	SFPAX
	ENC12	NEMA 4/IP65 Enclosure for EPAX	ENC12000
	SHR	Shroud for EPAX	SHREPA00
	EN/SH	EPAX NEMA 4/IP65 Enclosure and Shroud	EPAXENSH

*Refer to "Selecting Your Display Components and Option Cards."

**Available as a FREE download from the Red Lion website. www.redlion-controls.com

TROUBLESHOOTING

For technical assistance, contact technical support.

LIMITED WARRANTY

The Company warrants the products it manufactures against defects in materials and workmanship for a period limited to one year from the date of shipment, provided the products have been stored, handled, installed, and used under proper conditions. The Company's liability under this limited warranty shall extend only to the repair or replacement of a defective product, at The Company's option. The Company disclaims all liability for any affirmation, promise or representation with respect to the products.

The customer agrees to hold Red Lion Controls harmless from, defend, and indemnify RLC against damages, claims, and expenses arising out of subsequent sales of RLC products or products containing components manufactured by RLC and based upon personal injuries, deaths, property damage, lost profits, and other matters which Buyer, its employees, or sub-contractors are or may be to any extent liable, including without limitation penalties imposed by the Consumer Product Safety Act (P.L. 92-573) and liability imposed upon any person pursuant to the Magnuson-Moss Warranty Act (P.L. 93-637), as now in effect or as amended hereafter.

No warranties expressed or implied are created with respect to The Company's products except those expressly contained herein. The Customer acknowledges the disclaimers and limitations contained herein and relies on no other warranties or affirmations.