

**GUARDSCAN  
BPU 4  
BLANKING PROGRAMMING UNIT  
TECHNICAL MANUAL 343233-01  
English**

**WARNING**

**Guardscan photo-electric safety systems are intended to protect operators working at or near dangerous machinery. They can only perform this function if they are correctly fitted to a suitable machine. It is essential that the full contents of this manual and all the authoritative documents referred to herein are fully understood before any attempt at installation is made. If in doubt contact your authorised Guardscan distributor.**

**IMPORTANT**

**This manual must accompany the product throughout its working life. Those persons responsible for the product must ensure that all persons involved in the installation, commissioning, operation, maintenance and servicing of the product have access to all the information supplied by the manufacturers of the machine and its safety system.**

## **Guardscan Light Curtain Products are manufactured by:**

### **Tapeswitch Ltd**

Unit 38 Drumhead Road  
Chorley North Industrial Park  
Chorley  
PR6 7BX  
England

Tel : +44 (0) 1257 249777  
Fax : +44 (0) 1257 246600  
Email : [info@tapeswitch.co.uk](mailto:info@tapeswitch.co.uk)  
Web : [www.tapeswitch.co.uk](http://www.tapeswitch.co.uk)

## **The Tapeswitch Group**

### **Tapeswitch Corporation**

100 Schmitt Boulevard  
Farmingdale  
New York  
NY 11735  
USA

Tel : +1 631 630 0442  
Fax : +1 631 630 0454  
E-mail : [sales@tapeswitch.com](mailto:sales@tapeswitch.com)  
Web : [www.tapeswitch.com](http://www.tapeswitch.com)

### **Tapeswitch Ltd**

635 Newbold Street  
London  
Ontario  
Canada  
N6E 2T8

Tel : +1 519 681 2980  
Fax : +1 519 685 9318  
Email : [sales@londonmat.com](mailto:sales@londonmat.com)  
Web : [www.londonmat.com](http://www.londonmat.com)

### **Tapeswitch GmbH**

Postfach 10 20 23  
Walter-Bruch-Straße 13  
D-30982 Pattensen  
Germany

Tel : +49 (0) 5101 14490  
Fax : +49 (0) 5101 14499  
Email : [verkauf@tapeswitch.de](mailto:verkauf@tapeswitch.de)  
Web : [www.tapeswitch.de](http://www.tapeswitch.de)

### **Tapeswitch Japan**

5-11-23 Nakakasai - Hirano Bldg.  
Edogawa-ku,  
Tokyo  
Japan 134-0083

Tel : + 81 3 5676 5421  
Fax : + 81 3 5676 5422  
Email : [tsjapan@gc4.so-net.ne.jp](mailto:tsjapan@gc4.so-net.ne.jp)  
Web : [www.tsjapan.co.jp](http://www.tsjapan.co.jp)

# CONTENTS

## 1. INTRODUCTION

- 1.1 GENERAL
- 1.2 TYPES OF BLANKING
- 1.3 IMPLICATIONS OF BLANKING

## 2. BPU 4 PROGRAMMING UNIT

- 2.1 UNIT DESCRIPTION
- 2.2 PROGRAMMING INSTRUCTIONS
- 2.3 IMPORTANT CONSIDERATIONS

## 3. MANAGEMENT ISSUES

- 3.1 BLANKING TEST PROCEDURE
- 3.2 DETECTION CAPABILITY - TEST AND INDICATION
- 3.3 CHANGE OF OPERATING PARAMETERS

# 1. INTRODUCTION

## 1.1 GENERAL

### WARNING

**Incorrect use of blanking and/or failure to correctly address the implications of blanking on the management of a machine, is potentially very dangerous. It is therefore vital that the requirements for the use of blanking specified in this manual are fully understood and complied with.**

The Guardscan BPU4 unit is used to program the blanking function of a Guardscan light curtain which is equipped with this feature. This includes the GS 140 range of light curtains. Blanking originated in the U.S.A. but has since been generally adopted by manufacturers and users of light curtains worldwide.

Blanking is sometimes confused with other light curtain related functions, for example muting, and therefore it helps to start with an explanation of exactly what blanking is.

First consider the normal operation of a light curtain without blanking. A light curtain typically consists of a grid of parallel beams of infra-red light, each beam consisting of an emitter device at one end and a receiver device at the other (see Figure 1).

If any single beam is obscured, the light curtain will generate a stop signal.

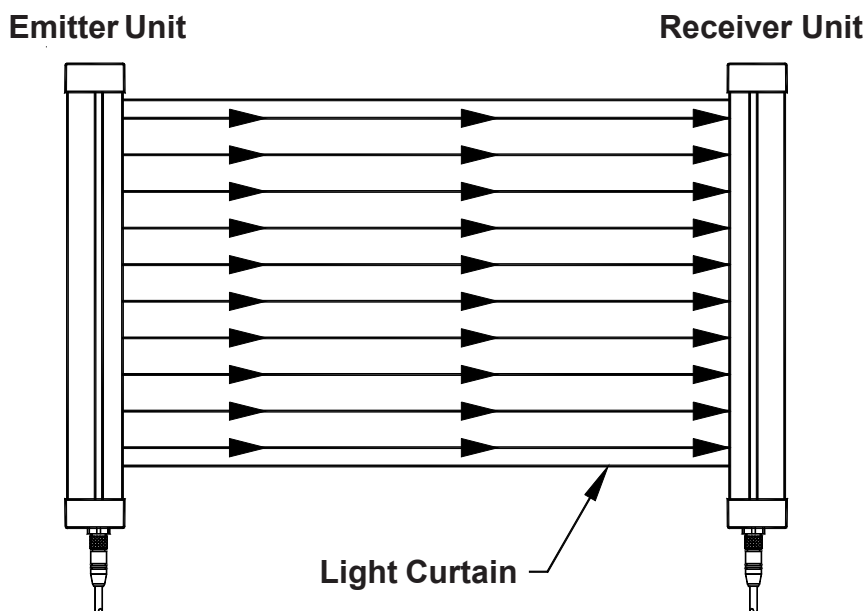
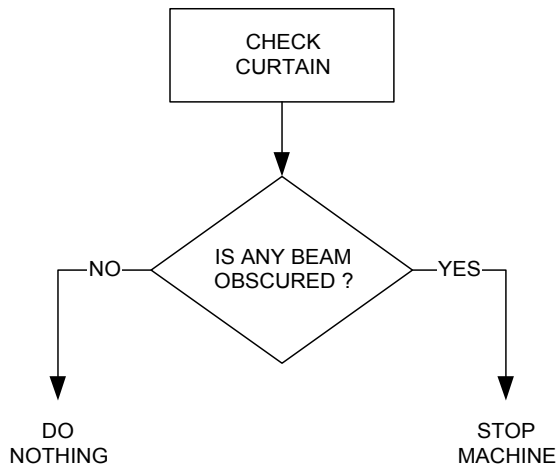

Figure 1

The decision process of the light curtain is a relatively simple one as shown in Figure 2.

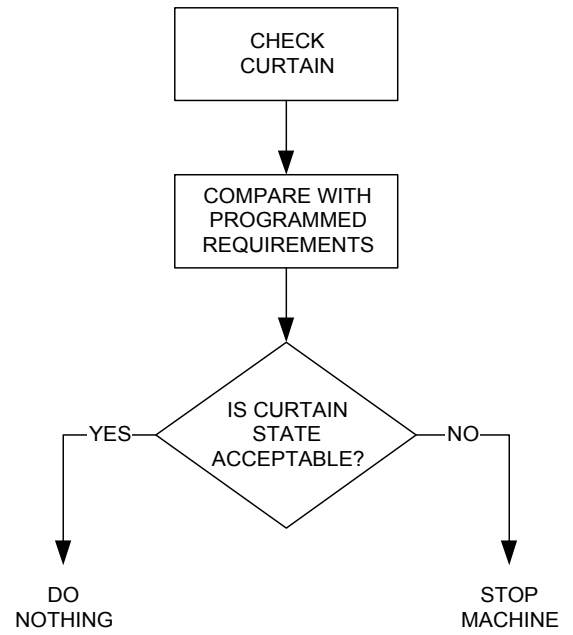

**Figure 2**

Now consider the operation of a light curtain with blanking. A light curtain with blanking is able to:

- (a) determine the state of each individual beam of its curtain
- (b) compare this information with previously programmed requirements
- (c) based on this comparison, decide whether to send a stop signal to the machine.

The light curtain decision process is now a more complex one as shown in Figure 3.



**Figure 3**

Blanking therefore modifies the basic instinct of the light curtain to stop the machine when any beam is obscured, and makes its response conditional.

Safe use of this modified behaviour obviously makes special demands on the design of the light curtain but equally important demands are made on the installation, programming, operation and maintenance of the machine/light curtain combination.

Notice that the light curtain can only consider the question:

'Has this state of the curtain been programmed as acceptable?'

It cannot consider the question:

'Is this a safe state for the curtain to be in?'

This is the responsibility of all those involved in the use of the machine and can only be achieved with careful consideration of all the implications of the use of blanking as described in this manual and careful analysis of the application.

## 1.2 TYPES OF BLANKING

### 1.2.1 GENERAL

There are basically two types of blanking: fixed and floating. The two types can be used independently or in combination. The operation, purpose and implications of independent and combined use are considered below.

### 1.2.2 FIXED BLANKING

In fixed blanking, one or more selected beams, at particular positions in the curtain, are allowed to be obscured without a stop signal being generated.

**Note: The behaviour of a fixed blanked beam can be further modified by the use of fixed and floating blanking in combination. This is explained in section 1.2.4.**

Fixed blanking is used where correct positioning of the light curtain dictates that some necessary fixtures on a machine, for example sheet supports on a press brake, will obscure some beams during normal operation.

These beams can be selected for fixed blanking so that the presence of the fixture does not cause the curtain to send a stop signal and the machine can be used normally. The curtain ignores the obstruction.

In the Guardscan GS 140 light curtain, once a beam has been specified as 'fixed blanked' it is monitored in 'opposite mode'. If a fixed blanked beam becomes unobscured, the light curtain will generate a stop signal, just as if a normal, non-blanked beam had been obscured.

If a fixed blanked beam is not monitored in this way, removal of the fixture would leave an unprotected area in the curtain.

In the Guardscan GS 140 system the programming of fixed blanked beams is achieved by means of a learning function.

Using the BPU 4, the light curtain is instructed to learn the state of the curtain, i.e. which beams are clear and which are obscured. This state is recorded in non-volatile memory. For this reason fixed blanking is also referred to as learned blanking later in this manual.

After programming, the current state of the curtain is continually compared with the recorded state and any deviations will result in a stop signal being generated.

### 1.2.3 FLOATING BLANKING

Floating blanking allows a number of beams, usually one or two, to be obscured without a stop signal being generated. The term floating blanking is used because an obstruction can move or 'float' within the detection zone without a stop signal being generated, providing that the obstruction does not obscure more than the specified number of beams.

Floating blanking is used to allow an obstruction to move within the detection zone, for example where flexible cables or pipes pass through the detection zone and can move whilst the machine is operating.

The Guardscan GS 140 light curtain can be programmed for 1 beam floating blanking or 2 beam floating blanking.

The maximum size of object which will be ignored by the curtain, at any range, is given in Table 1.

| BASIC<br>DETECTION<br>CAPABILITY | TYPE OF FLOATING<br>BLANKING USED |        |
|----------------------------------|-----------------------------------|--------|
|                                  | 1 BEAM                            | 2 BEAM |
| 14mm                             | 3mm                               | 11mm   |
| 30mm                             | 5mm                               | 21mm   |
| 70mm                             | 38mm                              | 88mm   |

**Table 1 - Ignored object diameter and ignored movement of fixed blanked object**

### 1.2.4 FIXED AND FLOATING BLANKING IN COMBINATION

When fixed and floating blanking are used in combination the floating blanking modifies the fixed blanking. Recall that floating blanking, used independently, allows a number of beams to be blocked without generating a stop signal. It allows a number of beams which would normally need to be clear to be obscured. In other words, it allows a number of curtain discrepancies.

This is how floating blanking works with fixed blanking. When a light curtain has been programmed for fixed blanking, some beams need to be clear and all other beams need to be obscured, otherwise a stop signal will be generated. The floating blanking allows a number of curtain discrepancies. So, beams which would normally need to be clear can be obscured and beams which would normally need to be obscured can be clear.

In the case of the Guardscan GS 140 light curtains the maximum number of allowed curtain discrepancies can be set at 1 or 2.

This would allow a fixed blanked object, for example feedstock, to move slightly during machine operation. The maximum allowable movement of a fixed blanked object with floating blanking is given in Table 1.

## 1.3 IMPLICATIONS OF BLANKING

### 1.3.1 EFFECT OF BLANKING ON DETECTION CAPABILITY

Blanking of any kind increases the detection capability of a light curtain. The detection capability of a light curtain is the smallest diameter of opaque object which the system can reliably detect.

**Note: An increase in detection capability is not an improvement. It means that the curtain is less sensitive to intrusions.**

The **basic detection capability**,  $D_b$ , of an unblanked Guardscan GS 140 light curtain is marked on the label fitted to each unit and will be 14mm, 30mm or 70mm.

The **effective detection capability**,  $D_e$ , of the light curtain which is blanked can be calculated using the following formula:

**Formula 1:**  $D_e = D_b + I (N_{fx} + N_{ft})$

where:

$I$  = beam increment (see Table 2)

$N_{fx}$  = number of beams in largest contiguous block of fixed blanked beams

$N_{ft}$  = number of floating blanked beams

| BASIC DETECTION CAPABILITY | INCREMENT, I |
|----------------------------|--------------|
| 14mm                       | 9mm          |
| 30mm                       | 17mm         |
| 70mm                       | 50mm         |

Table 2

**Note: Read sections 1.3.2 and 1.3.3 for guidance before using this formula.**

### 1.3.2 EFFECT OF BLANKING ON SEPARATION DISTANCE

As previously explained, the use of any type of blanking increases the detection capability. Detection capability is one of a number of factors used to calculate the separation distance, i.e. the distance at which the light curtain is positioned from the dangerous parts of the machine. (See the light curtain manual for further details).

Normally, the greater the detection capability the greater the separation distance, all other factors being equal. Certainly, the use of floating blanking always requires an increase in separation distance.

With detection capabilities of more than 70mm section 6.1.4 of EN999 applies. Additional risks have to be considered, e.g. creeping underneath the lowest beam, reaching over the highest beam or in between beams. Moreover recommended positions of highest and lowest beam are given.

However, when using fixed blanking, although fixed blanking always increases the detection capability of the light curtain, it is not always necessary to increase the separation distance. This depends entirely on the nature of the obstruction.

Figures 4 and 5 show two obstruction possibilities: complete obstruction and incomplete obstruction.

In the case of incomplete obstruction it is possible for a person to gain access to the dangerous parts, between and on either side of the obstructions, through the area which would have been covered by the fixed blanked beams.



Therefore, in the case of incomplete obstruction, the **effective** detection capability has been increased and the separation distance must be calculated using this increased value.

In the case of complete obstruction, it is not possible for a person to gain access to the dangerous parts of the machine through the area of the curtain which would have been covered by the fixed blanked beams. When the light curtain/obstruction is considered as a whole, the detection capability in the unobscured areas of the curtain is not **effectively** increased.

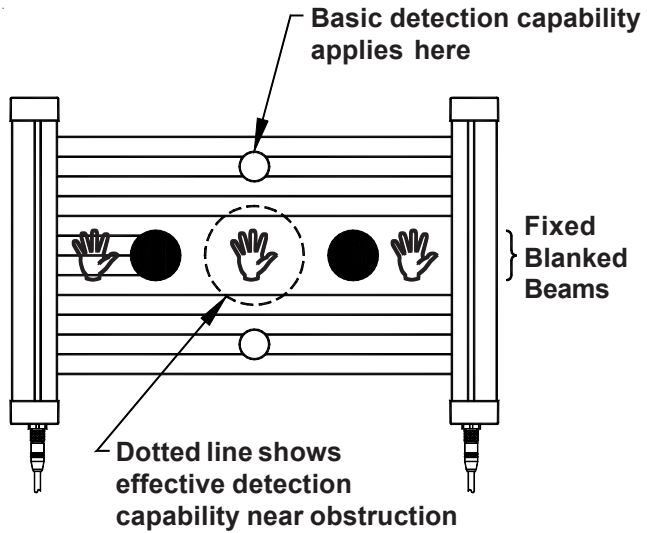

**Figure 4 Incomplete obstruction**

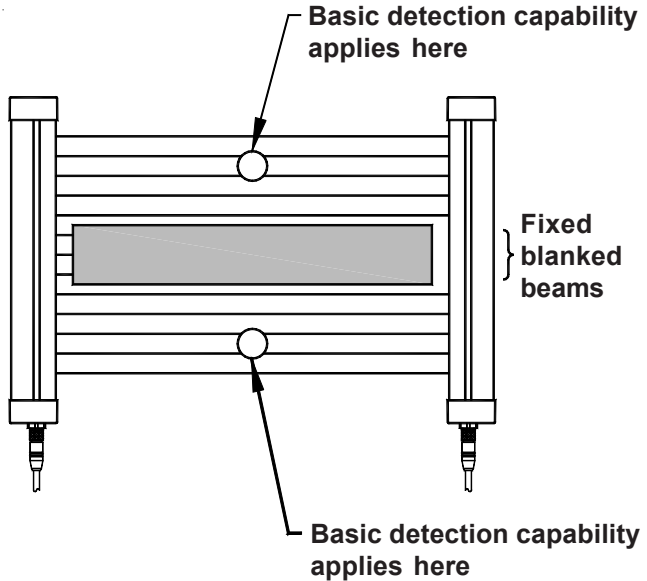

**Figure 5 Complete obstruction**

**GUARDSCAN**

Therefore, the separation distance can be calculated using the **basic** detection capability value.

It is important that an obstruction originally considered as complete is not modified at a later date such that the use of the basic detection capability value is no longer valid. If this cannot be assured, it is recommended that the application is treated as an incomplete obstruction from the outset and the separation distance calculated accordingly.

**Note: Any gaps between a complete obstruction and the light curtain units must not exceed the values recommended in EN294.**

Figure 6 shows a combined obstruction where, due to the shape of the obstruction, part of the curtain is completely obstructed and part of the curtain is incompletely obstructed. In this case the complete and incomplete parts of the obstruction should be treated separately.

In all cases, if the obstruction is removed, the opposite mode monitoring will take effect and will cause a stop signal to be generated.

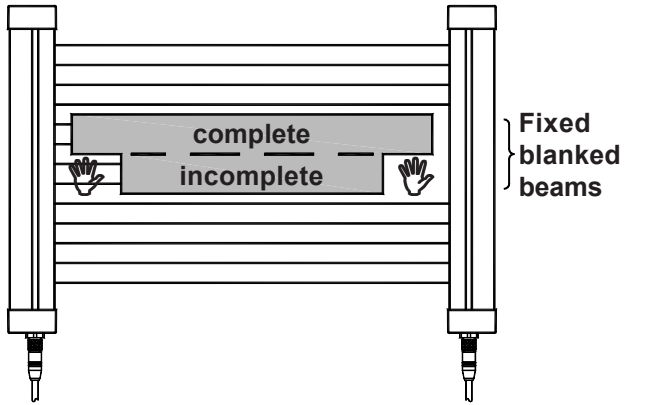

**Figure 6 Combined obstruction**

### 1.3.3 CALCULATION OF EFFECTIVE DETECTION CAPABILITY

The effective detection capability to be used for the purpose of calculating the separation distance can be determined as follows:

#### Case 1

Fixed blanking with complete obstruction:  
Basic detection capability applies.

#### Case 2

Fixed blanking with incomplete obstruction:  
Formula 1 applies.

#### Case 3

1 or 2 beam floating blanking only:  
Formula 1 applies (see Table 3 below).

#### Case 4

Fixed blanking with 1 or 2 beam floating blanking and complete obstruction:  
Formula 1 applies with  $N_{fx} = 0$ .

#### Case 5

Fixed blanking with 1 or 2 beam floating blanking and incomplete obstruction:  
Formula 1 applies.

**Note: If there are a number of obstructions in the same curtain the above calculation must be made for each obstruction and the largest value found should be used in the calculation of separation distance.**

| BASIC DETECTION CAPABILITY | 1 BEAM FLOATING | 2 BEAM FLOATING |
|----------------------------|-----------------|-----------------|
| 14mm                       | 23mm            | 32mm            |
| 30mm                       | 47mm            | 64mm            |
| 70mm                       | 120mm           | 170mm           |

Table 3

Full details of the calculation of separation distance can be found in the technical manual for the light curtain and in the European standard EN999.

For cases 2 and 5 above, if the number of beams which are fixed blanked ( $N_{fx}$ ) is not clear the following procedure can be used:

1. Measure the largest obstruction, where it obscures the curtain.
2. Divide the measurement by the appropriate increment,  $I$ , shown in Table 2.
3. Add 0.25 to the answer **then** round up to the next integer.
4. Use this value for the term  $N_{fx}$ .

**Example:** A vertical light curtain with a basic detection capability of 30mm is incompletely obstructed by horizontal sheet supports with section 48mm x 48mm.

The value of  $I$  for a curtain with basic detection capability of 30mm is 17mm (from Table 2).

48 divided by 17 gives 2.82

Adding 0.25 gives 3.07

Rounding up to next integer gives 4

Using  $N_{fx} = 4$  in Formula 1 gives:

$$D_e = 30 + 17(4 + 0)$$

$$D_e = 98\text{mm}$$

Use this value for detection capability when calculating separation distance.

## 2. BPU 4

### 2.1 UNIT DESCRIPTION

The programming unit Guardscan BPU 4 is required to program the blanking function of a Guardscan GS 140 system.

The BPU 4 unit is connected in-line between the receiver unit and the machine as shown in Figure 7.

The BPU 4 has five indicators and two buttons. The front panel of the BPU 4 is shown in Figure 8.

Four of the indicators are associated with the four types of blanking:

- No Blanking
- Learned (Fixed) Blanking
- 1 Beam Floating Blanking
- 2 Beam Floating Blanking

Because these can be used in combination there are six possible programmed modes:

- No Blanking
- Learned (Fixed) Blanking
- 1 Beam Floating Blanking
- 2 Beam Floating Blanking
- Learned with 1 Beam Floating Blanking
- Learned with 2 Beam Floating Blanking

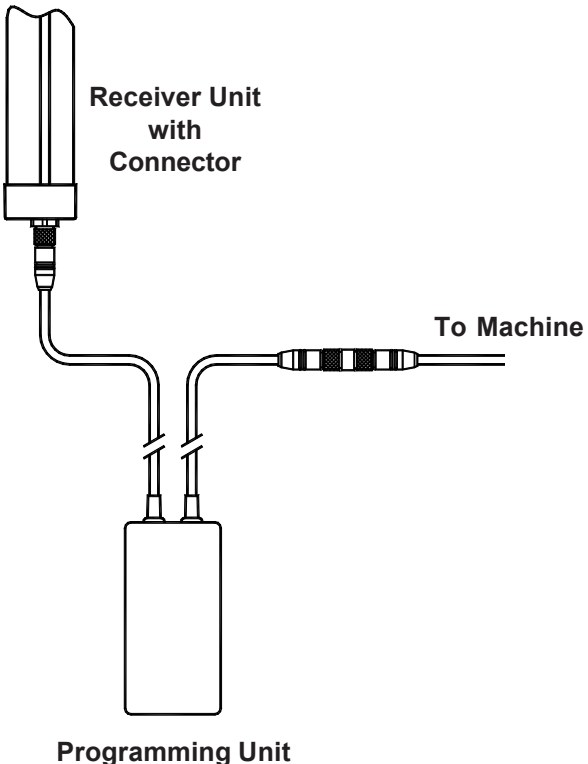

Figure 7

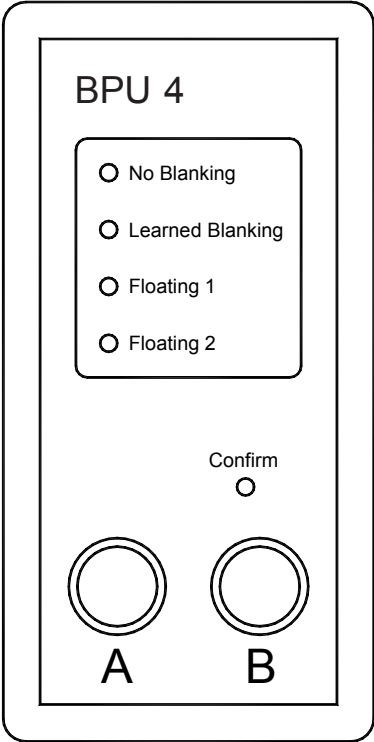
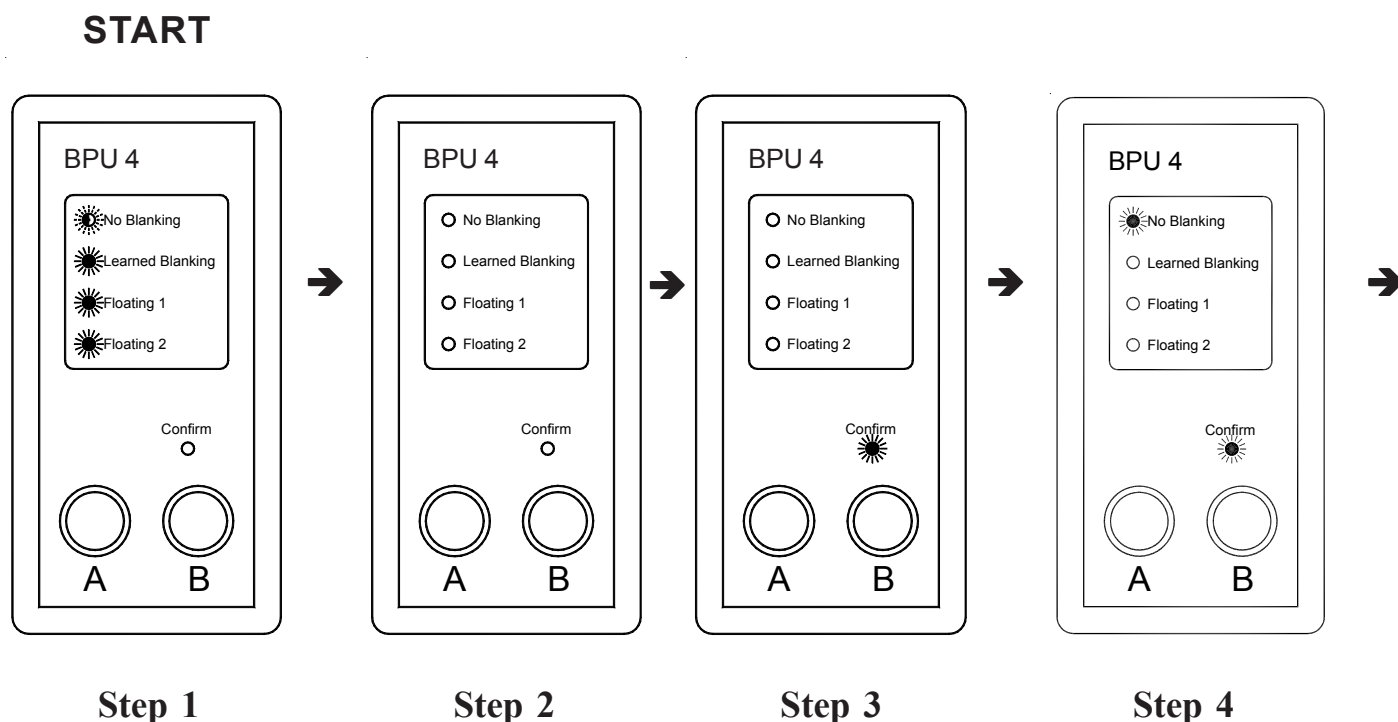

Figure 8

## 2.2 PROGRAMMING INSTRUCTIONS

The basic programming sequence is illustrated and described below:



1. Connect the programming unit in-line with the receiver unit. All the mode indicators will come ON with the current mode indicator(s) flashing.

2. To enter programming mode, press buttons A and B together for 3 seconds. The mode indicators will go OFF.

3. After a short period the confirm indicator will come ON and then go OFF. Button B must be pressed within 3 seconds of the confirm indicator coming ON.

4. If steps 2 and 3 are followed correctly the indicators for the current mode will be ON steady, together with the confirm LED.

Pressing button A repeatedly will cycle the indicators forward through the possible blanking modes and illuminate the confirm LED.

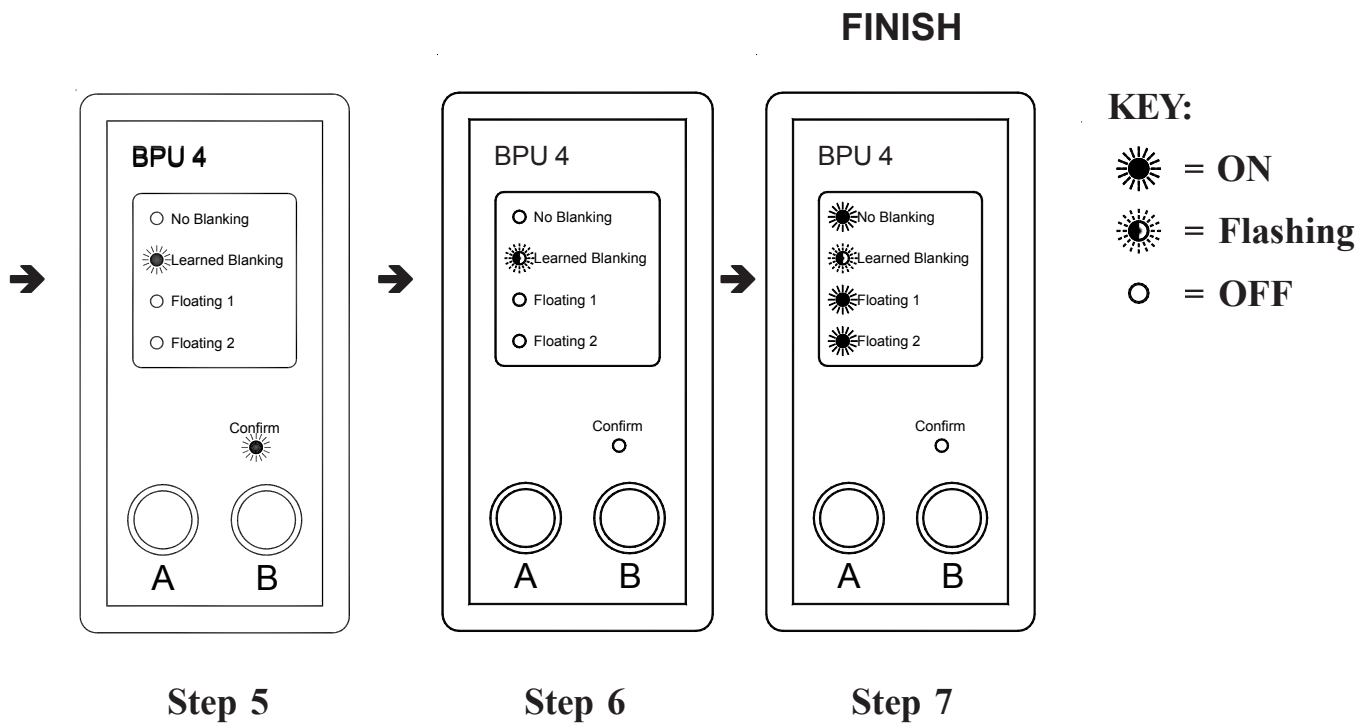

**Figure 9**

5. To program a particular mode, press button B and the desired mode indicator will come ON.

6. Once the selected mode has been programmed all the other indicators will come ON steady and the programmed mode indicators will flash.

7. After a short period, providing the curtain is in an acceptable state, the outputs will come ON. The system is now in the initial state. Disconnect the programming unit from the light curtain.

## 2.3 OPERATING CONSIDERATIONS

### 2.3.1 BPU 4 OPERATION

The following points should be observed when using the BPU 4.

1. Beam 1, the beam nearest the connector end of the emitter and receiver units, cannot be blanked in any way. If beam 1 is obscured, the outputs will go OFF.

2. When the BPU 4 unit is attached to the light curtain initially, check that all the mode indicators illuminate.

3. Once programming mode has been entered, if no buttons are pressed for a period of ten seconds, programming will automatically abort and the previous programmed mode will be resumed. Similarly if an inappropriate sequence of button operations is performed the programming will automatically abort. Automatic aborting will be indicated by all the mode indicators illuminating for a period of five seconds.

4. The machine cannot be operated with the BPU 4 connected to the light curtain. It is recommended that the BPU 4 unit is held by a responsible person when not in use.

5. If no beams are obstructed, learned blanking will not program. If the selected mode is learned blanking or **includes** learned blanking, the light curtain will default to the selected mode **minus** learned blanking. For example if learned blanking only is selected, the light curtain will default to no blanking; if learned blanking with 2 beam floating blanking is selected the light curtain will default to 2 beam floating blanking only.

6. If the light curtain is in test mode (indicated by the red indicator on the emitter unit being lit steady) the programming unit will not function.

7. If the communication link between the light curtain and the BPU 4 unit is not functioning all the mode indicators will flash whilst the BPU 4 is connected.

### 2.3.2 CURTAIN OPERATION

When a light curtain is programmed for blanking of any type, the yellow indicator on the light curtain receiver unit will be lit steady.

### 3. MANAGEMENT ISSUES

#### 3.1 BLANKING TEST PROCEDURE

Immediately prior to programming the light curtain for learned (fixed) blanking (with or without floating blanking) it is essential that the light curtain is tested as follows:

1. With the light curtain in its intended position on the machine but with no obstruction in place, program the light curtain for 'No blanking'. Check that all the indicators of the BPU4 unit illuminate when the programming unit is initially attached to the light curtain. A faulty indicator could lead to programming of the wrong mode.

If any indicator does not illuminate, **DONOT USE THE PROGRAMMING UNIT UNTIL IT HAS BEEN REPAIRED.**

2. Perform the daily test on the light curtain system, as detailed in the light curtain technical manual, using the test piece supplied with the light curtain (i.e. the test piece with a diameter which is the same as the detection capability marked on the light curtain unit labels).

If this test fails **DO NOT USE FIXED BLANKING UNTIL THE LIGHT CURTAIN HAS BEEN REPAIRED.**

3. If the test is passed, without moving the light curtain, fit the obstructions in place and program the desired blanking mode.

This test ensures that faulty beams, which may not be obscured by the obstruction, are not inadvertently blanked.

#### 3.2 DETECTION CAPABILITY - TEST AND INDICATION

When blanking is in use the detection capability can be affected such that the detection capability marked on the light curtain units is not correct. This also means that the test piece supplied with the light curtain is no longer suitable for performing the daily tests.

Previous sections of this manual describe how to determine the effective detection capability for any blanking situation.

A test piece will need to be obtained or produced to suit the effective detection capability, in order to perform the daily tests.

Also it is recommended that the current effective detection capability of a system be recorded and clearly displayed at the machine.

#### 3.3 CHANGE OF OPERATING PARAMETERS

If any operating parameter relating to the guard or the machine is changed, i.e. the obstruction removed or the guard repositioned it is essential to ensure that the blanking test procedure specified in section 3.1 is carried out.

**Use this page for notes and calculations**