

Simple-to-use ELECYLINDER with Built-in Controller
Small & Medium 2-Finger Gripper Standard Type

EC GRB8/10M

Simple-to-use ELECYLINDER with Built-in Controller
Large 2-Finger Gripper Standard & High-thrust Type

EC GRB13M/L

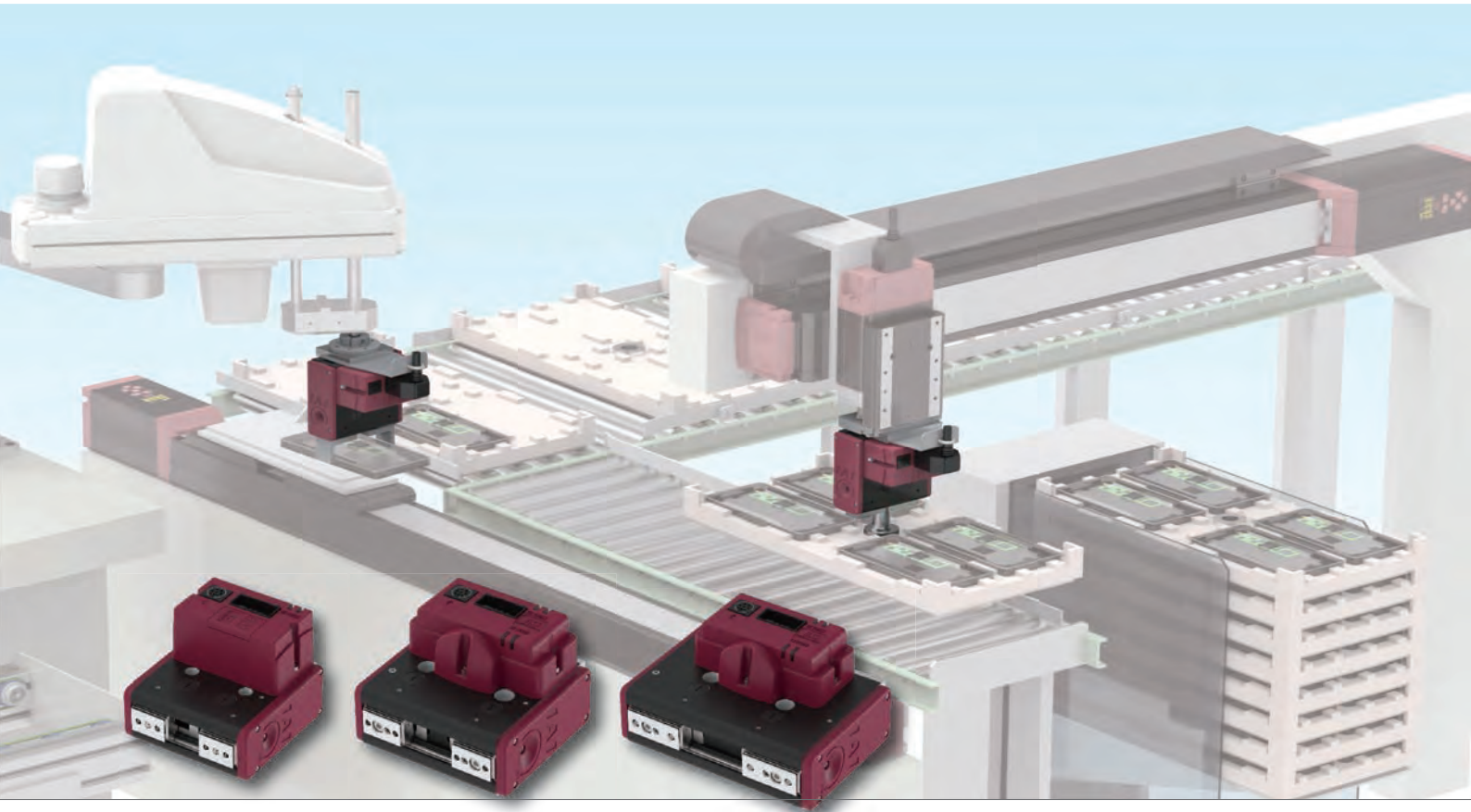

EC ELECYLINDER

Simple & Wireless
Operation
2 Position Actuator



01 Easy setting

Teaching pendant [TB-03] simple data setting screen

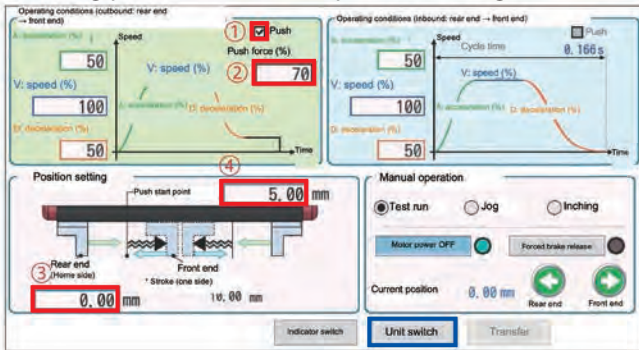

*Screen

Setting complete in just 4 steps!

- Step 1** Check "Push" ← Gripping is done with push-motion operation.
- Step 2** Set push force ← Setting by switching to Newton display (guideline value) with "Unit switch" is also possible.
- Step 3** Set standby position
- Step 4** Set push start point

02 Easy cable setup

Supports

4-way cable exit

Cable fixing bracket (front/top) can be selected as an option.

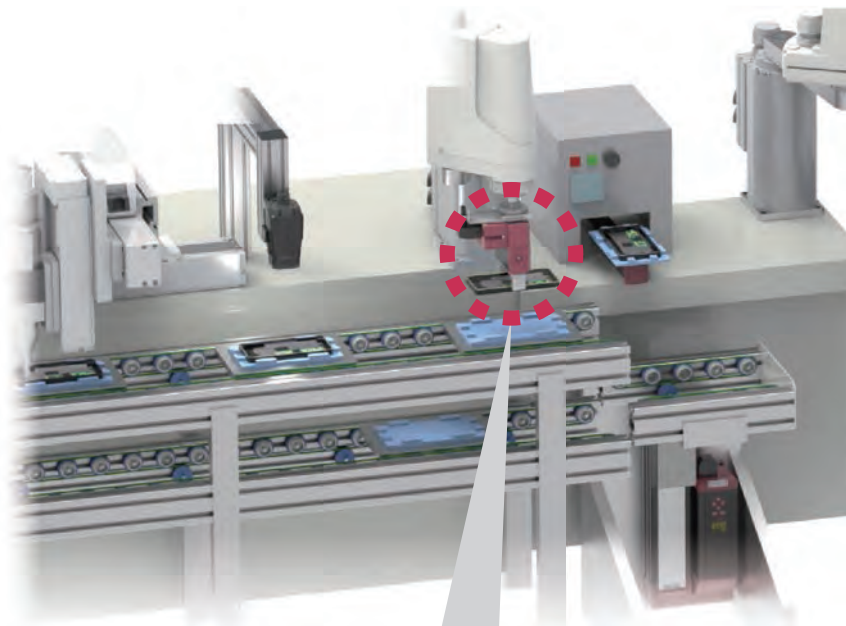
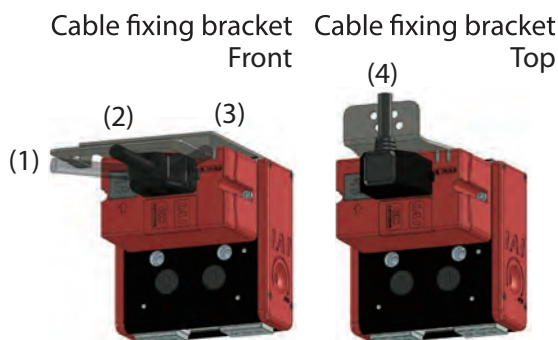

Convenient!

- Select "4-way connector cable" to change the cable exit freely among four directions. (Details on P. 20)
- Combine with the cable fixing bracket for easier, stable cable setup.

Cable fixing bracket (top)
Cable tie (included)



Gripper Type



03 Built-in controller

Wireless connection available Helps keep equipment simple

Simple!

Used with TB-03:

- Communication cable is not required
- Wireless operation such as setting, test run, alarm confirmation etc. is possible
- Up to 16 axes can be connected (each axis can also be named)

→ Connection is easy even for combined axes and inaccessible equipment.

Teaching pendant TB-03 Approx. 5m (guideline)

Recommended!

- Built-in controller saves equipment space
- Operation is possible with ON/OFF control alone
- Just connect a single ø7.2 cable to complete the wiring

→ Ideal for combined products.

*Wiring example

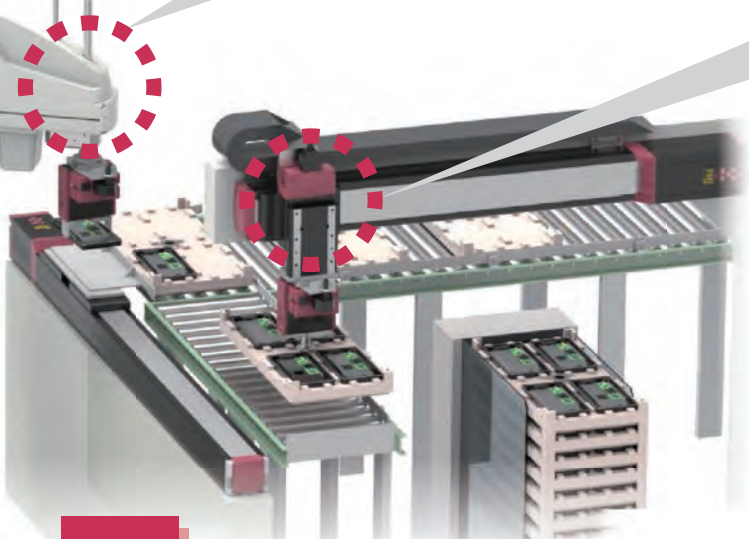

04 Low price

05 Four variations available

Type	Small type	Medium type	Large type	
	GRB8M	GRB10M	Standard	High thrust
Stroke (one side)	10mm	15mm	20mm	
Maximum grip force (both sides)	28N	100N	150N	360N

← High grip force!

Model Specification Items

EleCylinder

EC

Series

Type

Deceleration ratio

Stroke (both sides)

Power / I/O cable length

Option

GRB8	Gripper 82mm width
GRB10	Gripper 98mm width
GRB13	Gripper 130mm width

<GRB8>

M	Trapezoidal screw Lead 1.5mm Pulley deceleration ratio 1.5
---	--

<GRB10>

M	Trapezoidal screw Lead 1.5mm Pulley deceleration ratio 1.15
---	---

<GRB13>

M	Standard	Trapezoidal screw Lead 2mm Pulley deceleration ratio 1.25
L	High thrust	Trapezoidal screw Lead 2mm Pulley deceleration ratio 2.50

<GRB8>

20	20mm (One side 10mm)
----	-------------------------

<GRB10>

30	30mm (One side 15mm)
----	-------------------------

<GRB13>

40	40mm (One side 20mm)
----	-------------------------

0	No cable Power I/O connector included (Note)
(S)1	1m
?	?
(S)10	10m

(every 1m)

(S): Cable with 4-way connector
(Note) A power I/O connector is not included if RCON-EC connection specification (ACR) is selected

Left blank	Incremental encoder specification NPN specification, no options
ACR	RCON-EC connection specification *1
FST	Cable fixing bracket (front)
NM	Non-motor end specification
PN	PNP specification *1
TMD2	Split motor and controller power supply specification *1
TST	Cable fixing bracket (top) *2
WA	Battery-less absolute encoder specification *3
WL	Wireless communication specification
WL2	Wireless axis operation specification

*1 "PN" and "TMD2" cannot be selected when "ACR" is selected.

*2 Can be selected only when selecting the cable with 4-way connector.

*3 Available only for GRB10/GRB13.

Mounting Method

● Mounting surface A screw hole fixed

● Mounting surface B screw hole fixed

● Mounting surface B through hole fixed

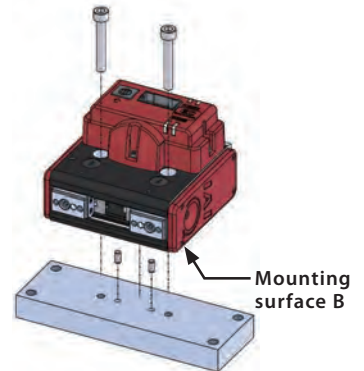
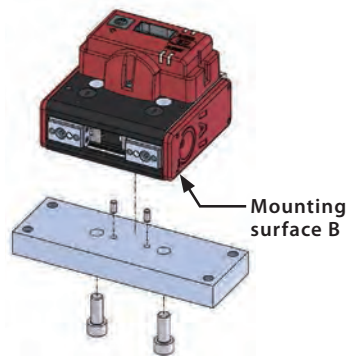
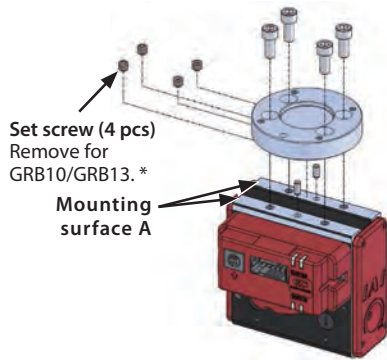





* Plugged with a set screw to prevent contamination with foreign matter.

Precautions for Mounting

● Mounting orientation

○: Can be mounted

		Mounting orientation			
					
Series	Type	Horizontal mounting on flat surface	Vertical mounting	Horizontal mounting to side	Horizontal mounting suspended
EC	GRB8				
	GRB10	○	○	○	○
	GRB13				

● Keep the body installation surface and workpiece mounting surface flatness within 0.05mm/m.
Uneven flatness will increase the sliding resistance of the finger and may cause a malfunction.

Gripper selection method

Selection process

Step 1

Confirmation of required grip force and conveyable workpiece weight



Step 2

Confirmation of grip point distance



Step 3

Confirmation of external force applied to finger

Step 1 Confirmation of required grip force and conveyable workpiece weight

When gripping the workpiece with friction force derived from grip force, the required grip force is calculated as below.

(1) For normal conveyance

F: Grip force (N): Total value of each finger's push force
μ: Static friction coefficient between finger attachment and workpiece
m: Workpiece mass (kg)
g: Gravitational acceleration (= 9.8m/s²)

- Conditions under which workpiece will not fall when gripped statically

$$F\mu > mg \quad F > \frac{mg}{\mu}$$

- Required grip force at recommended safety ratio 2 in normal conveyance

$$F > \frac{mg}{\mu} \times 2 \text{ (safety ratio)}$$

- At friction coefficient μ0.1 to 0.2

$$F > \frac{mg}{0.1 \sim 0.2} \times 2 = (10 \sim 20) \times mg$$

For normal workpiece conveyance (guideline)

Required grip force ▶ 10 to 20x or more workpiece weight
 Conveyable workpiece weight ▶ 1/10 to 1/20 or less of grip force

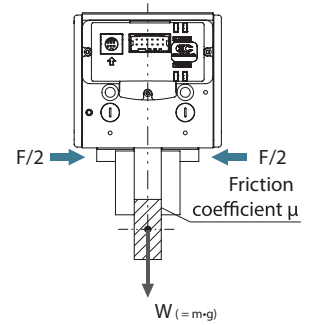

*While the conveyable workpiece weight increases with the static friction coefficient, select a model offering grip force of 10 to 20x or more for safety purposes.

(2) When large acceleration/deceleration or impact force is applied while moving the workpiece

In addition to gravity, even stronger inertial force operates on the workpiece.

In this case, select a model with an even higher safety ratio.

When large acceleration/deceleration or impact is applied (guideline)

Required grip force ▶ 30 to 50x or more workpiece weight
 Conveyable workpiece weight ▶ 1/30 to 1/50 or less of grip force

Step 2 Confirmation of grip point distance

Use with distance (L, H) from finger mounting surface to grip point within the range below.

Use beyond the limited range will cause excess moment to operate on the finger sliding part and interior mechanisms, negatively affecting operation life.

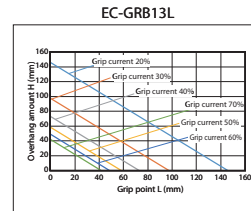
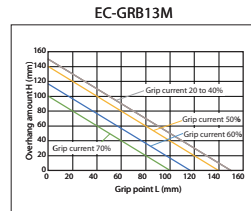
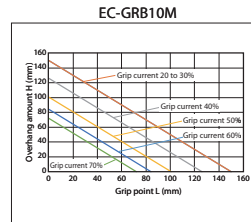
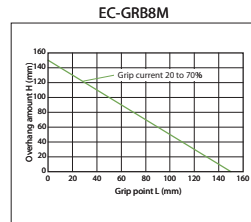

<Distance to grip point>

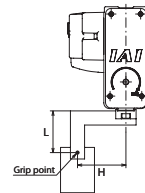

<Moment offset reference position>

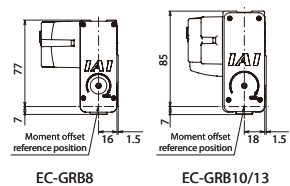

Even with the grip point distance within the limit range, keep the finger attachment as small and lightweight as possible.

A larger and longer finger or a heavier one may cause performance to deteriorate or negatively affect the guide part, due to inertial force and bending moment when opening and closing.

Gripper selection method

Step 3 Confirmation of external force applied to finger

(1) Vertical allowable load

Check that the vertical allowable load applied to each finger does not exceed the allowable value.

(2) Allowable load moment

Calculate M_a and M_c with L and M_b with H . Check that the moment applied to each finger does not exceed the maximum allowable load moment.

- Allowable external force with moment load applied to each finger

$$\text{Vertical allowable load } F \text{ (N)} > \frac{\text{Maximum allowable load moment (N}\cdot\text{m)}}{L \text{ or } H \text{ (mm)} \times 10^{-3}}$$

Calculate the vertical allowable load F (N) for both L and H .

Confirm that the external force applied to the finger does not exceed the calculated vertical allowable load F (N) (the smaller value of L and H).

Model	Vertical allowable load F (N)	Maximum allowable load moment (N·m)		
		M_a	M_b	M_c
EC-GRB8	598	3.60	3.60	10.2
EC-GRB10	598	3.60	3.60	10.2
EC-GRB13	898	7.52	7.52	15.3

1. The allowable value above is a static value. 2. Indicates the allowable value for one finger.

*Finger and workpiece weight are also parts of external force.

As well, external force applied to the finger also includes the centrifugal force when the gripper is rotated with the workpiece gripped and the inertial force due to acceleration/deceleration when moving.

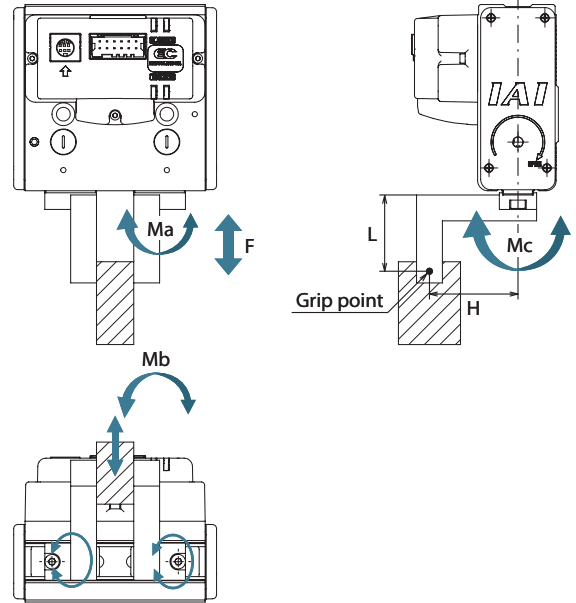

*The load point above indicates the position where the load is applied to the finger.

The position varies depending on the load type.

- Load due to grip force: Grip point
- Load due to gravity: Center mass location
- Inertial force when moving or centrifugal force when rotating: Center mass location

Load moment is the total value calculated for each load type.

Guidelines for Grip Point Distance and Grip Force

1. Graph shows grip force of grip point distance when maximum grip force is set to 100%.
2. Grip point distance refers to the distance (L or H) from the finger attachment mounting surface to the grip point.
3. Grip force varies by individual items. Consider this as a guideline.

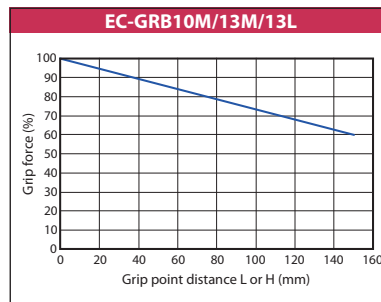
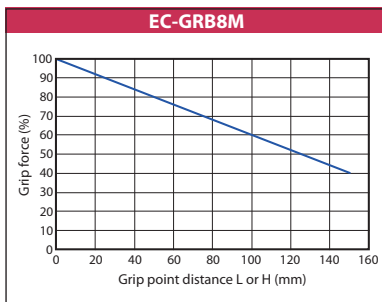

EC-GRB8

Slider

2-Finger

Body Width
80
mm

24v
Pulse
Motor

Model Specification Items			
EC	GRB8	M	20
Series	Type	Deceleration ratio	Stroke
		M	20
		Trapezoidal screw Lead 1.5mm Pulley deceleration ratio 1.5	20mm (One side 10mm)
			Power / I/O cable length
			Refer to Power / I/O cable length below
			Option
			Refer to Option below

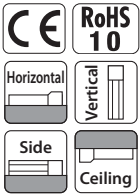

- POINT

Selection Notes

 - (1) The maximum open/close speed in the Main Specifications represents the operation speed for one side. The relative operation speed is twice the value.
 - (2) The maximum grip force in the Main Specifications is the total of the grip force of both fingers when the grip point distance and overhang distance are both 0. For the workpiece weight which can actually be conveyed, refer to the Confirmation of Grip Point Distance.
 - (3) When gripping the workpiece, be sure to use push-motion operation.
 - (4) The workpiece grip force will be maintained via self-lock even during power cutoffs. To release the workpiece being gripped during a power cutoff, turn the open/close screw on the side, or remove the finger attachment to release the workpiece.

Main Specifications

Item	Description
Lead	Trapezoidal screw lead (mm) 1.5 Pulley deceleration ratio 1.5
Grip operation	Max. grip force (N) (both sides) 28 Max. speed during grip operation (mm/s) (one side) 5 Max. speed (mm/s) (one side) 45
Approach operation	Min. speed (mm/s) (one side) 5 Rated acceleration/deceleration (G) (one side) 0.3 Max. acceleration/deceleration (G) (one side) 0.3
Brake	Brake specification - Brake holding force (kgf) -
Stroke (one side)	Min. stroke (mm) (one side) 10 Max. stroke (mm) (one side) 10

Item	Description
Drive system	Trapezoidal screw ø8
Positioning repeatability	±0.05mm
Lost motion	- (notation not available due to 2-point positioning function)
Backlash (one side)	0.2mm or less
Linear guide	Limited guide
Static allowable moment	Ma: 3.60N·m Mb: 3.60N·m Mc: 10.2N·m
Vertical allowable load (Note 1)	598N
Ambient operating temperature, humidity	0 ~ 40°C, 85%RH or less (no condensation)
Degree of protection	-
Vibration/shock resistance	4.9m/s ²
Overseas standards	CE marking, RoHS directive
Motor type	Pulse motor (□□20)
Encoder type	Incremental (no setting for battery-less absolute option)
Number of encoder pulses	800 pulse/rev

Slide type moment direction

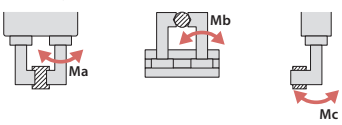

Power / I/O cable length

Standard connector cable

Cable code	Cable length	User wiring specification (flying leads)	RCON-EC connection specification (Note 1) (with connectors on both edges)
0	No cable	Terminal block supplied (Note 2)	CB-REC-PWBIO□□□-RB supplied
1 ~ 3	1 ~ 3m	CB-EC-PWBIO□□□-RB supplied	
4 ~ 5	4 ~ 5m		
6 ~ 7	6 ~ 7m		
8 ~ 10	8 ~ 10m		

(Note 1) If RCON-EC connection specification (ACR) is selected as an option.
 (Note 2) Only terminal block connector is included. Please refer to P. 17 for details.
 (Note) Robot cable is standard.

4-way connector cable

Cable code	Cable length	User wiring specification (flying leads)	RCON-EC connection specification (Note 1) (with connectors on both edges)
S1 ~ S3	1 ~ 3m	CB-EC2-PWBIO□□□-RB supplied	CB-REC2-PWBIO□□□-RB supplied
S4 ~ S5	4 ~ 5m		
S6 ~ S7	6 ~ 7m		
S8 ~ S10	8 ~ 10m		

(Note 1) If RCON-EC connection specification (ACR) is selected as an option.
 (Note) Robot cable is standard.

(Note 1) Use at a load exceeding the value above could reduce operation life or lead to damage.

Options

Name	Option code	Reference page
RCON-EC connection specification (Note 1)	ACR	13
Cable fixing bracket (front)	FST	13
Non-motor end specification	NM	13
PNP specification	PN	13
Split motor and controller power supply specification	TMD2	14
Cable fixing bracket (top) (Note 2)	TST	14
Wireless communication specification	WL	14
Wireless axis operation specification	WL2	14

(Note 1) If the RCON-EC connection specification (ACR) is selected, the PNP specification (PN) and split motor and controller power supply specification (TMD2) cannot be selected.
 (Note 2) Can be selected only when selecting the 4-way connector cable.

Confirmation of Grip Point Distance

Use with distance (L, H) from finger (jaw) mounting surface to grip point within the range in the graph.

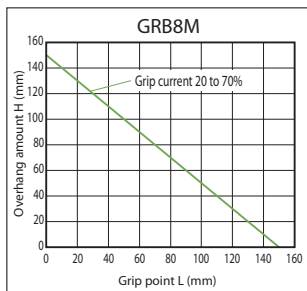
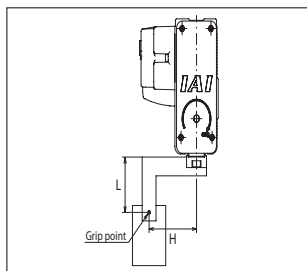

(Note) Use beyond the limited range will cause excess moment to operate on the finger sliding part and interior mechanisms, negatively affecting operation life.

Grip Force

Correlation between grip force and current limit value

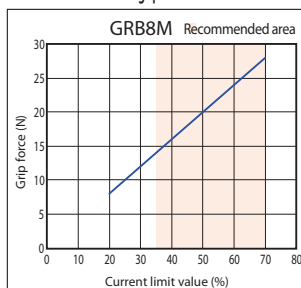

(Note) Total value of both fingers when grip point distance (L, H) is 0.
 (Note) Guideline values. There is variation of 0 to 60%. In particular, current limit values set outside the recommended range (colored part of the graph) are more likely to lead to variation.
 (Note) For gripping (pushing), the speed is fixed at 5mm/s.

Guidelines for grip point distance and grip force

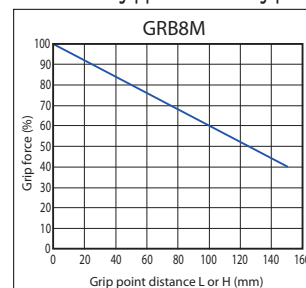

(Note) Shows grip force of overhang position when maximum grip force is set to 100%. The results may differ due to the rigidity of the finger attachment used.

Dimensions

(Note) The opening side is home as standard. To set the closing side as home, designate the option (model: NM).

CAD drawings can be downloaded from our website.

www.intelligentactuator.de

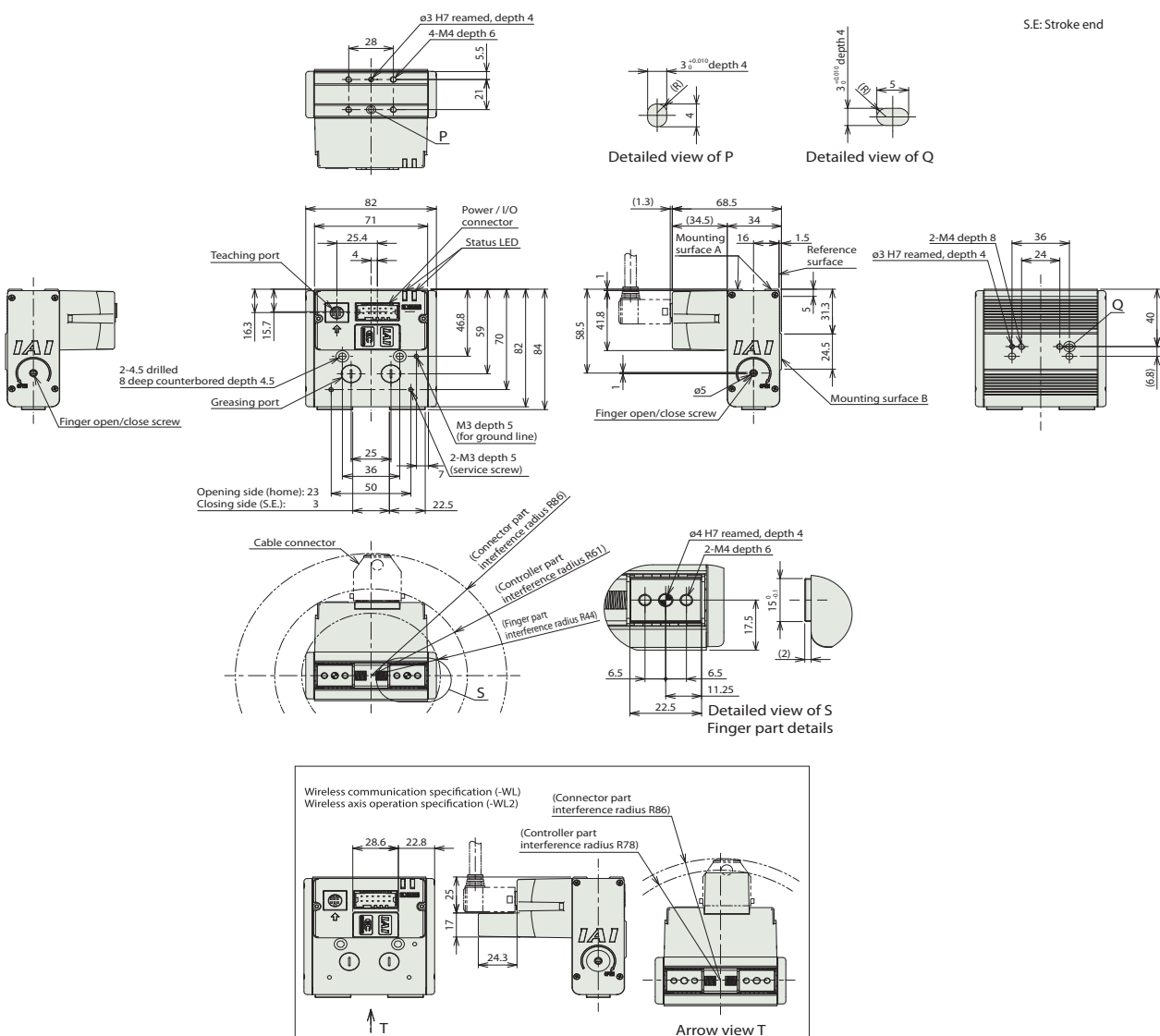

Mass

Item	Description
Mass	0.51kg

Applicable Controllers

(Note) The EC series is equipped with a built-in controller. Please refer to P. 16 for details on built-in controllers.

EC-GRB10

Slider

2-Finger

Body Width
100
mm

24v
Pulse
Motor

Model Specification Items

EC	GRB10	M	30		
Series	Type	Deceleration ratio	Stroke	Power / I/O cable length	Option
		M Trapezoidal screw Lead 1.5mm Pulley deceleration ratio 1.15	30 30mm (One side 15mm)	Refer to Power / I/O cable length below	Refer to Option below

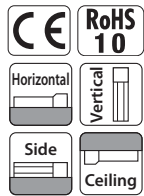

- POINT Selection Notes**
- (1) The maximum open/close speed in the Main Specifications represents the operation speed for one side. The relative operation speed is twice the value.
 - (2) The maximum grip force in the Main Specifications is the total of the grip force of both fingers when the grip point distance and overhang distance are both 0. For the workpiece weight which can actually be conveyed, refer to the Confirmation of Grip Point Distance.
 - (3) When gripping the workpiece, be sure to use push-motion operation.
 - (4) The workpiece grip force will be maintained via self-lock even during power cutoffs. To release the workpiece being gripped during a power cutoff, turn the open/close screw on the side, or remove the finger attachment to release the workpiece.

Main Specifications

Item	Description	
Lead	Trapezoidal screw lead (mm)	1.5
	Pulley deceleration ratio	1.15
Grip operation	Max. grip force (N) (both sides)	100
	Max. speed during grip operation (mm/s) (one side)	5
Approach operation	Max. speed (mm/s) (one side)	95
	Min. speed (mm/s) (one side)	5
	Rated acceleration/deceleration (G) (one side)	0.3
	Max. acceleration/deceleration (G) (one side)	0.3
Brake	Brake specification	-
	Brake holding force (kgf)	-
Stroke (one side)	Min. stroke (mm) (one side)	15
	Max. stroke (mm) (one side)	15

Item	Description
Drive system	Trapezoidal screw ø8
Positioning repeatability	±0.05mm
Lost motion	- (notation not available due to 2-point positioning function)
Backlash (one side)	0.2mm or less
Linear guide	Limited guide
Static allowable moment	Ma: 3.60N·m
	Mb: 3.60N·m
	Mc: 10.2N·m
Vertical allowable load (Note 1)	598N
Ambient operating temperature, humidity	0 ~ 40°C, 85%RH or less (no condensation)
Degree of protection	-
Vibration/shock resistance	4.9m/s ²
Overseas standards	CE marking, RoHS directive
Motor type	Pulse motor (□28)
Encoder type	Incremental (standard) /battery-less absolute (option)
Number of encoder pulses	800 pulse/rev

Slide type moment direction

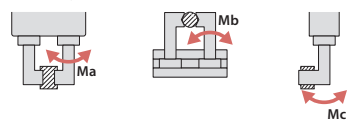

Power / I/O cable length

Standard connector cable

Cable code	Cable length	User wiring specification (flying leads)	RCON-EC connection specification (Note 1) (with connectors on both edges)
0	No cable	Terminal block supplied (Note 2)	CB-REC-PWBIO□□□-RB supplied
1 ~ 3	1 ~ 3m	CB-EC-PWBIO□□□-RB supplied	
4 ~ 5	4 ~ 5m		
6 ~ 7	6 ~ 7m		
8 ~ 10	8 ~ 10m		

(Note 1) If RCON-EC connection specification (ACR) is selected as an option.
 (Note 2) Only terminal block connector is included. Please refer to P. 17 for details.
 (Note) Robot cable is standard.

4-way connector cable

Cable code	Cable length	User wiring specification (flying leads)	RCON-EC connection specification (Note 1) (with connectors on both edges)
S1 ~ S3	1 ~ 3m	CB-EC2-PWBIO□□□-RB supplied	CB-REC2-PWBIO□□□-RB supplied
S4 ~ S5	4 ~ 5m		
S6 ~ S7	6 ~ 7m		
S8 ~ S10	8 ~ 10m		

(Note 1) If RCON-EC connection specification (ACR) is selected as an option.
 (Note) Robot cable is standard.

Options

Name	Option code	Reference page
RCON-EC connection specification (Note 1)	ACR	13
Cable fixing bracket (front)	FST	13
Non-motor end specification	NM	13
PNP specification	PN	13
Split motor and controller power supply specification	TMD2	14
Cable fixing bracket (top) (Note 2)	TST	14
Battery-less absolute encoder specification	WA	14
Wireless communication specification	WL	14
Wireless axis operation specification	WL2	14

(Note 1) If the RCON-EC connection specification (ACR) is selected, the PNP specification (PN) and split motor and controller power supply specification (TMD2) cannot be selected.
 (Note 2) Can be selected only when selecting the 4-way connector cable.

Confirmation of Grip Point Distance

Use with distance (L, H) from finger (jaw) mounting surface to grip point within the range in the graph.

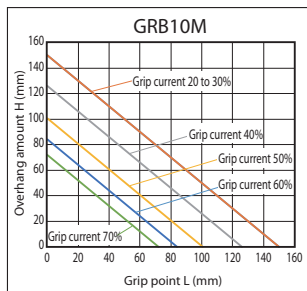
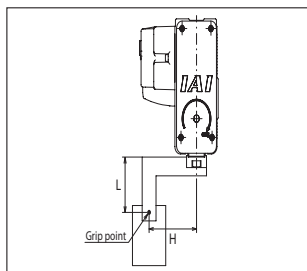

(Note) Use beyond the limited range will cause excess moment to operate on the finger sliding part and interior mechanisms, negatively affecting operation life.

Grip Force

Correlation between grip force and current limit value

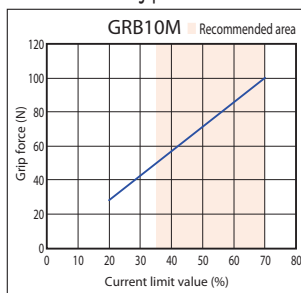

(Note) Total value of both fingers when grip point distance (L, H) is 0.
 (Note) Guideline values. There is variation of 0 to 60%. In particular, current limit values set outside the recommended range (colored part of the graph) are more likely to lead to variation.
 (Note) For gripping (pushing), the speed is fixed at 5mm/s.

Guidelines for grip point distance and grip force

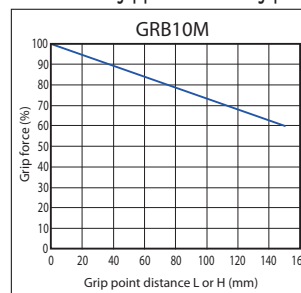

(Note) Shows grip force of overhang position when maximum grip force is set to 100%. The results may differ due to the rigidity of the finger attachment used.

Dimensions

*1 Plugged with a set screw to prevent contamination with foreign matter. Remove when using mounting surface A.
 (Note) The opening side is home as standard. To set the closing side as home, designate the option (model: NM).

CAD drawings can be downloaded from our website.
www.intelligentactuator.de



S.E: Stroke end

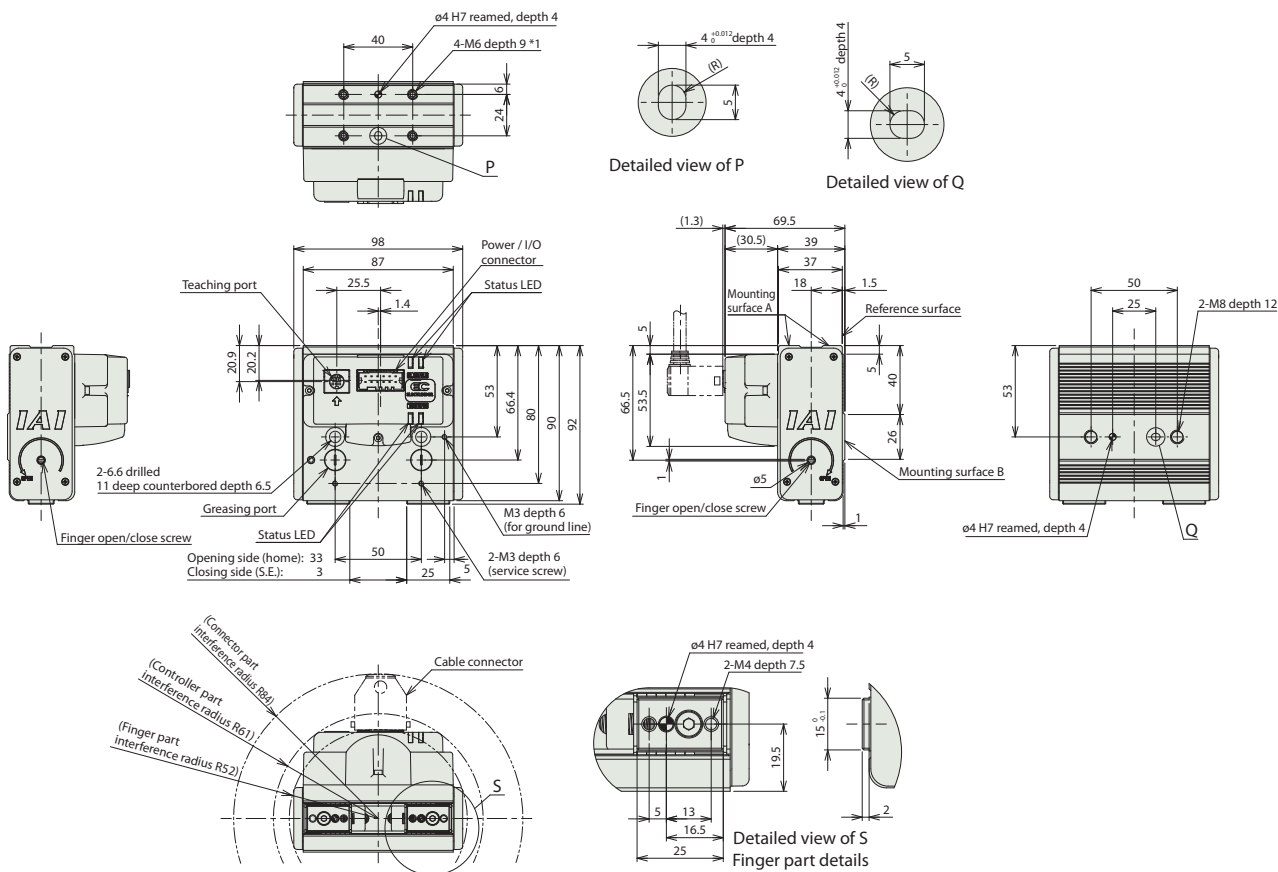

Mass

Item	Description
Mass	0.69kg

Applicable Controllers

(Note) The EC series is equipped with a built-in controller. Please refer to P. 16 for details on built-in controllers.

Confirmation of Grip Point Distance

Use with distance (L, H) from finger (jaw) mounting surface to grip point within the range in the graph.

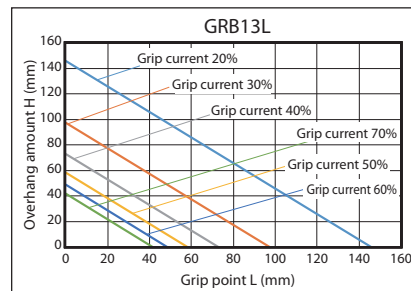
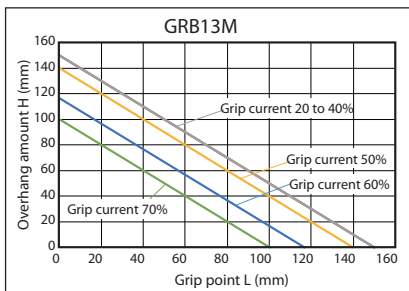
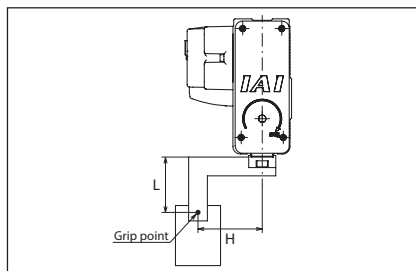

(Note) Use beyond the limited range will cause excess moment to operate on the finger sliding part and interior mechanisms, negatively affecting operation life.

Grip Force

Correlation diagrams between grip force and current limit value

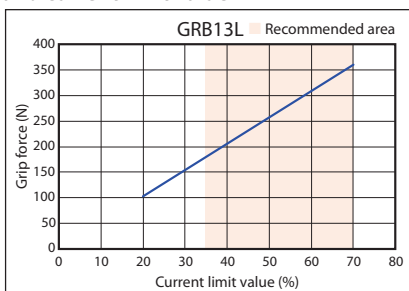
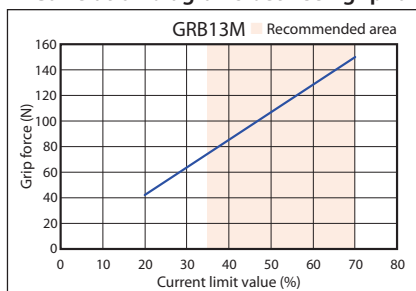

Guidelines for grip point distance and grip force

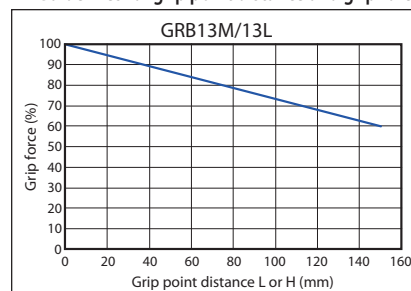

(Note) Total value of both fingers when grip point distance (L, H) is 0.
 (Note) Guideline values. There is variation of 0 to 60%. In particular, current limit values set outside the recommended range (colored part of the graph) are more likely to lead to variation.
 (Note) For gripping (pushing), the speed is fixed at 5mm/s.

(Note) Shows grip force of overhang position when maximum grip force is set to 100%. The results may differ due to the rigidity of the finger attachment used.

Dimensions

*1 Plugged with a set screw to prevent contamination with foreign matter. Remove when using mounting surface A.

(Note) The opening side is home as standard. To set the closing side as home, designate the option (model: NM).

CAD drawings can be downloaded from our website.

www.intelligentactuator.de

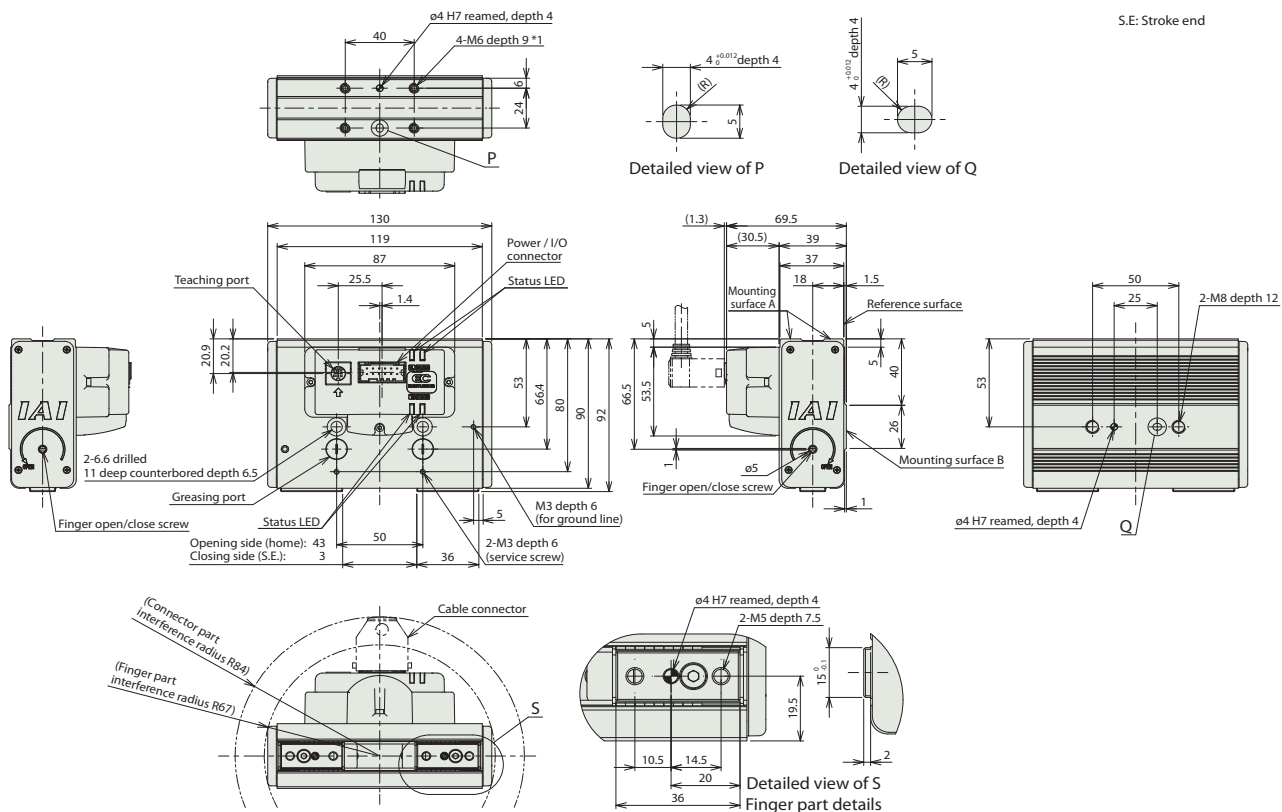

Mass

Item	Description
Mass	0.99kg

Applicable Controllers

(Note) The EC series is equipped with a built-in controller. Please refer to P. 16 for details on built-in controllers.

EleCylinder Series Options

RCON-EC connection specification *Cannot be selected with the TMD2 and PN options (the ACR option includes the split motor and controller power supply specification)

Model **ACR** **Applicable models** All models

Description This option should be selected to connect over an R-unit to a field network.
*If this option is selected, the power supply must be a twin power supply and the input/output specification must be NPN. Therefore, it cannot be selected with the TMD2 or PN options.

Cable fixing bracket (front)

Model **FST** **Applicable models** All models

Description This is a bracket used to fix the cable near the connector with a cable tie. The teaching port can be accessed even with the fixing bracket mounted. (However, the teaching port cannot be accessed when the cable exit direction is on the teaching port side, due to interference.)
*Not assembled before shipment. Refer to the drawings for mounting instructions.
When fixing the gripper on mounting surface A, co-fasten with the cable fixing bracket.



EC-GRB8 Individual model number EC-FST-GRB8
(Individual weight: 0.1kg / Material: Stainless steel)

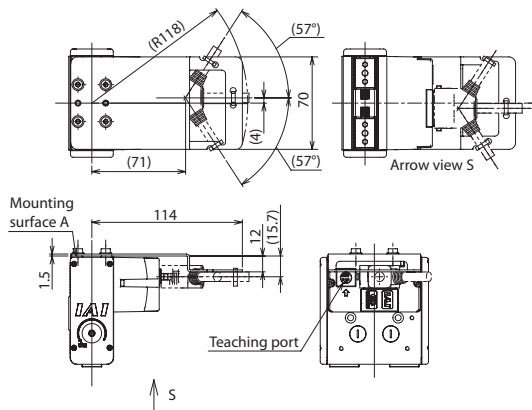

- ◆ Accessories other than fixing brackets
 - Flange head hex bolts (stainless steel): M4 x 6 (4 pcs)
 - Cable tie (1 pc)

EC-GRB10/GRB13 Individual model number EC-FST-GRB1013
(Individual weight: 0.11kg / Material: Stainless steel)

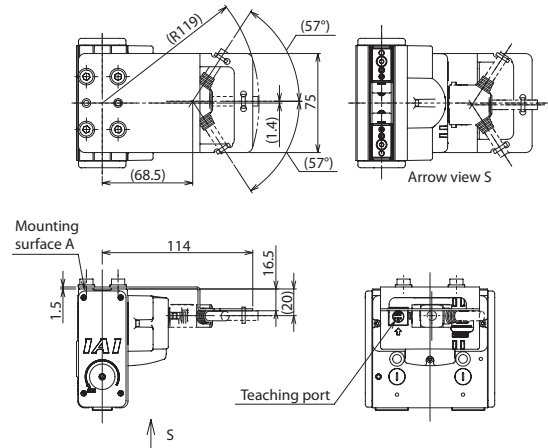

- ◆ Accessories other than fixing brackets
 - Flange head hex bolts (stainless steel): M6 x 10 (4 pcs)
 - Cable tie (1 pc)

Non-motor end specification

Model **NM** **Applicable models** All models

Description The home position is normally set to the finger opening side. This option is for setting the home position on the other side in order to accommodate variations in equipment layout, etc. (Because the home position is adjusted to the factory default for shipping, when changing home after delivery the product must be returned to IAI for adjustment.)

PNP specification *Cannot be ordered simultaneously with the ACR option, which is NPN specification.

Model **PN** **Applicable models** All models

Description EC Series products provide NPN specification input/output for connecting external devices as standard. Specifying this option changes input/output to the PNP specification.

Twin power supply specification * Cannot be selected with the ACR option (the RCON-EC connection specification is a split motor and controller power supply specification)

Model **TMD2** **Applicable models** All models

Description This option includes an actuator operation stop input. Select this option to allow shutting down the actuator drive power only. Please refer to P. 17 for more information on wiring.

Cable fixing bracket (top)

Model **TST** **Applicable models** All models

Description This is a bracket used to fix the cable near the connector with a cable tie. The teaching port can be accessed even with the fixing bracket mounted.
 *Can be selected only when selecting the 4-way connector cable.
 *Not assembled before shipment. Refer to the drawings for mounting instructions.
 When fixing the gripper on mounting surface A, co-fasten with the cable fixing bracket.



EC-GRB8 Individual model number EC-TST-GRB8 (Individual weight: 0.06kg / Material: Stainless steel)

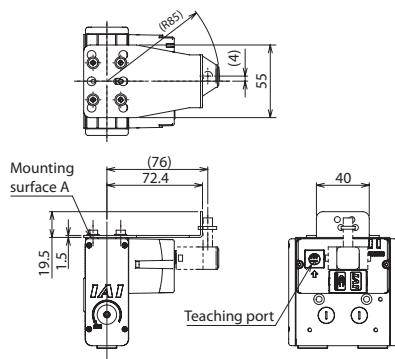

- ◆ Accessories other than fixing brackets
 - Flange head hex bolts (stainless steel): M4 x 6 (4 pcs)
 - Cable tie (1 pc)

EC-GRB10/GRB13 Individual model number EC-TST-GRB1013 (Individual weight: 0.06kg / Material: Stainless steel)

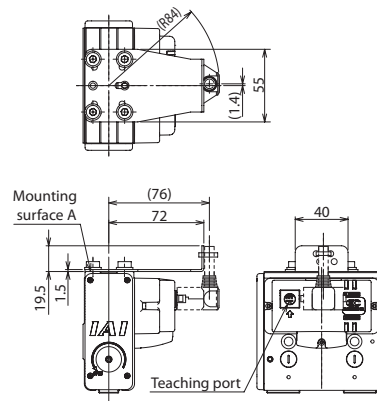

- ◆ Accessories other than fixing brackets
 - Flange head hex bolts (stainless steel): M6 x 10 (4 pcs)
 - Cable tie (1 pc)

Battery-less absolute encoder specification

Model **WA** **Applicable models** EC-GRB10/GRB13

Description Incremental encoder specification is standard. Specifying this option installs a built-in battery-less absolute encoder.

Wireless communication specification

Model **WL** **Applicable models** All models

Description This option enables support for wireless communication. Specifying this option enables wireless communication with the TB-03 teaching pendant. The start point, end point, and AVD can be adjusted via wireless communication.

Wireless axis operation specification

Model **WL2** **Applicable models** All models

Description Specifying WL2 allows the product to operate wirelessly as with WL (start point, end point, and AVD adjustment), and also to perform axis travel operation tests (forward end/backward end movement, jog, and inching). However, this function is not meant to perform automatic operation. Please refer to P. 118 of the EC Catalog V10 for precautions on axis operations using a wireless connection. (Note) Customers cannot change WL to WL2, or WL2 to WL. Please contact IAI for this.

System Configuration

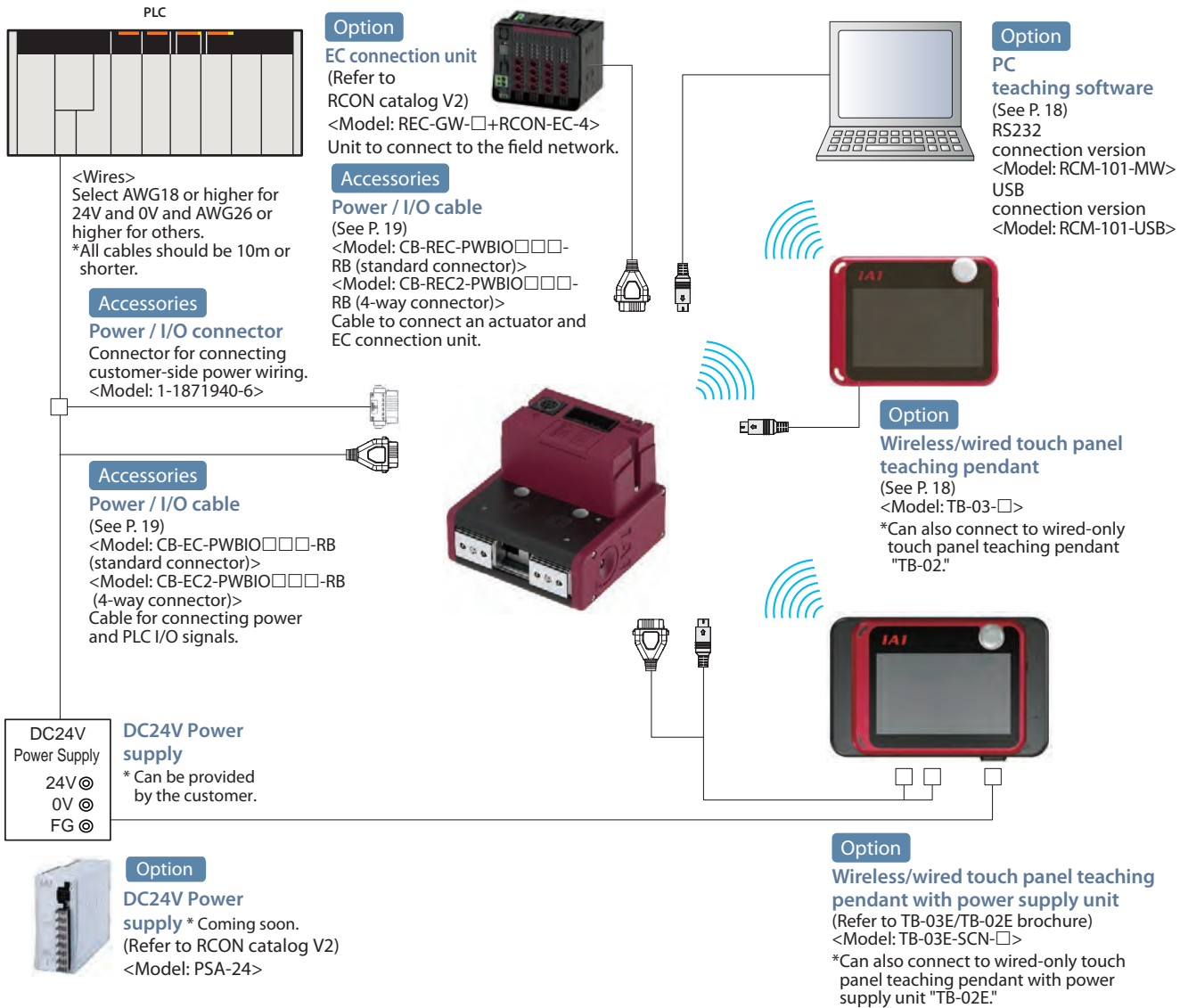

List of Accessories

■ Power / I/O cables, connectors

[Standard connector]

Product category		Accessories
Power / I/O cable length (selected with actuator model)	RCON-EC connection specification (ACR) selection	
0	None	Power / I/O connector (1-1871940-6)
	Yes	—
1 ~ 10	None	Power / I/O cable (CB-EC-PWBIO□□□-RB)
	Yes	Power / I/O cable (CB-REC-PWBIO□□□-RB)

[Four-way connector]

Product category		Accessories
Power / I/O cable length (selected with actuator model)	RCON-EC connection specification (ACR) selection	
S1 ~ S10	None	Power / I/O cable (CB-EC2-PWBIO□□□-RB)
	Yes	Power / I/O cable (CB-REC2-PWBIO□□□-RB)

Basic Controller Specifications

Specification item		Specification content	
Number of controlled axes		1 axis	
Power supply voltage		24VDC ±10%	
Power capacity	GRB8	Max. 1A (with energy-saving setting enabled only, including control power 0.3A)	
	GRB10, GRB13	Max. 2A (with energy-saving setting enabled only, including control power 0.3A)	
Generated heat (at duty ratio 100%)	GRB8	2W	
	GRB10, GRB13	5W	
Inrush current (Note 1)		2A	
Momentary power failure resistance		Max 500µs	
Motor size	GRB8	□20	
	GRB10, GRB13	□28	
Motor rated current	GRB8	0.4A	
	GRB10, GRB13	1.2A	
Motor control system		Weak field-magnet vector control	
Supported encoders		Incremental (800 pulse/rev), battery-less absolute encoder (800 pulse/rev)	
SIO		RS485 1ch (Modbus protocol compliant)	
PIO	Input specification	No. of inputs	3 points (forward, backward, alarm clear)
		Input voltage	24VDC ±10%
		Input current	5mA per circuit
		Leakage current	Max. 1mA/1 point
		Isolation method	Non-isolated
	Output specification	No. of outputs	3 points (forward complete, backward complete, alarm)
		Output voltage	24VDC ±10%
		Output current	50mA/1 point
		Residual voltage	2V or less
		Isolation method	Non-isolated
Data setting, input method		PC teaching software, touch panel teaching pendant, digital speed controller	
Data retention memory		Position and parameters are saved in non-volatile memory (no limit to number of rewrites)	
LED display	Controller status display	Servo ON (green light ON) / Alarm (red light ON) / Initializing when power comes ON (orange light ON) / Minor failure alarm (green/red alternately blinking) / Operation from teaching: Stop from teaching (red light ON) / Servo OFF (light OFF)	
	Wireless status display	Initializing wireless hardware, without wireless connection, or connecting from TP board (light OFF) / Connecting through wireless (green blinking) / Wireless hardware error (red blinking) / Initializing when power comes ON (orange light ON)	
Predictive maintenance/preventative maintenance		When the number of movements or operation distance has exceeded the set value and when the LED (right side) blinks alternately green and red at overload warning *Only when configured in advance	
Ambient operating temperature		0 ~ 40°C	
Ambient operating humidity		85% RH or less (no condensation or freezing)	
Operating environment		No corrosive gas or excessive dust	
Insulation resistance		500VDC 10MΩ	
Electric shock protection mechanism		Class 1 basic insulation	
Cooling method		Natural air cooling	

(Note 1) Inrush current flows for approximately 5ms after the power is input. (At 40°C) Inrush current value differs depending on the impedance on the power line.

Solenoid Valve Method

EleCylinder products normally use a double solenoid method.

Change parameter No. 9 ("Solenoid valve type selection") to use the single solenoid method.

<Caution>

Operation cannot be performed using the single solenoid method when operating connected to RCON-EC.

I/O (Input/Output) Specifications

I/O		Input	Output	
Specifications	Input voltage	24VDC ±10%	Load voltage	24VDC ±10%
	Input current	5mA per circuit	Maximum load current	50mA/1 point
	ON/OFF voltage	ON voltage: Min. 18VDC OFF voltage: Max. 6VDC	Residual voltage	2V or less
	Leakage current	Max. 1mA/1 point	Leakage current	Max. 0.1mA/1 point
Isolation method		Non-isolated from external circuit		
I/O logic	NPN			
	PNP			

(Note) Isolation method is non-isolated. When grounding an external device (such as a PLC) connected to EleCylinder, use the same ground as EleCylinder.

I/O Signal Wiring Diagram

I/O		Standard specification	Split motor and controller power supply specification (option model:TMD2)
Power / I/O connector		<p>0V A1 (Reserved) A2 Backward complete A3 Forward complete A4 Alarm output A5 (Reserved) A6</p> <p>B1 24V B2 Brake release (Note 1) B3 Backward command (Note 2) B4 Forward command (Note 2) B5 Alarm clear B6 (reserved)</p>	<p>Drive power and control power are separate for the TMD2 specification.</p> <p>0V A1 24V (control) A2 Backward complete A3 Forward complete A4 Alarm output A5 (Reserved) A6</p> <p>B1 24V (drive) B2 Brake release (Note 1) B3 Backward command (Note 2) B4 Forward command (Note 2) B5 Alarm clear B6 (reserved)</p>
I/O logic	NPN	<p>0V 24V</p>	<p>0V 24V</p>
	PNP	<p>24V 0V</p>	<p>24V 0V</p>

(Note 1) The EleCylinder gripper type has no brakes. Wiring is not required.

(Note 2) Switching to the single solenoid method will change B3 to "Forward/backward command" and B4 to "Unused."

I/O Signal Table

Power / I/O connector pin assignment			
Pin No.	Connector nameplate name	Signal abbreviation	Function overview
B3 (Note 1)	Backward	ST0	Backward command
B4 (Note 1)	Forward	ST1	Forward command
B5	Alarm clear	RES	Alarm clear
A3	Backward complete	LS0/PE0	Backward complete/push complete
A4	Forward complete	LS1/PE1	Forward complete/push complete
A5	Alarm	*ALM	Alarm detection (b-contact)
B2 (Note 2)	Brake release	BKRLS	Brake forced release (for brake equipped specification)
B1 (Note 3)	24V	24V	24V input
A1	0V	0V	0V input
A2 (Note 3)	(24V)	(24V)	24V input

(Note 1) Switching to the single solenoid method will change B3 to "Forward/backward" and B4 to "Unused". However, the power / I/O connector display will still read "B3:Backward" and "B4: Forward".

(Note 2) The EleCylinder gripper type has no brakes. Wiring is not required.

(Note 3) B1 is 24V (drive) and A2 is 24V (control) for the split motor and controller power supply specification (TMD2).

Option

Wireless/wired touch panel teaching pendant

Features This teaching device supports wireless connections. Start point/end point/AVD input and axis operation can be performed wirelessly.

Model TB-03- Please contact IAI for the current supported versions.

Configuration Wireless or wired connection



Specifications

Rated voltage	24VDC
Power consumption	3.6W or less (150mA or less)
Ambient operating temperature	0 ~ 40°C
Ambient operating humidity	5 ~ 85%RH (no condensation)
Environmental resistance	IPX0
Mass	Approx. 485g (body) + approx. 175g (battery)
Charging method	Wired connection with dedicated adapter/controller
Wireless connection	Bluetooth 4.2 class2

Teaching software for PC (Windows only)

Features The start-up support software which comes equipped with functions such as position teaching, trial operation, and monitoring. A complete range of functions needed for making adjustments contributes to shortened start-up time.

Model RCM-101-MW (with an external device communication cable + RS232 conversion unit)

Please contact IAI for the current supported versions.

Configuration

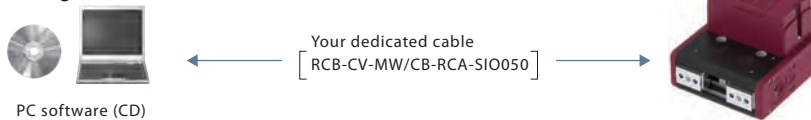

Model RCM-101-USB (with an external device communication cable + USB conversion adapter + USB cable)

Please contact IAI for the current supported versions.

Configuration

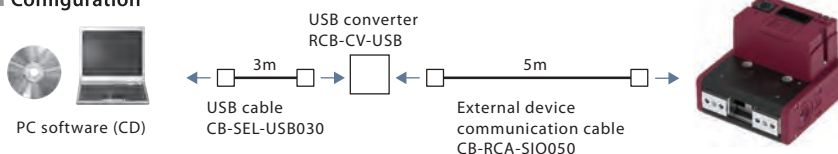

Maintenance Parts

When placing an order for a replacement cable after purchasing a product, please use the model name shown below.

■ Table of compatible cables

Cable type	Cable model
Power / I/O cable (user-wired specification)	CB-EC-PWBIO□□□-RB
Power / I/O cable (user-wired specification, four-way connector)	CB-EC2-PWBIO□□□-RB
Power / I/O cable (RCON-EC connection specification)	CB-REC-PWBIO□□□-RB
Power / I/O cable (RCON-EC connection specification, four-way connector)	CB-REC2-PWBIO□□□-RB

Model **CB-EC-PWBIO□□□-RB**

*Please indicate the cable length (L) in □□□ (for example, 030 = 3m)

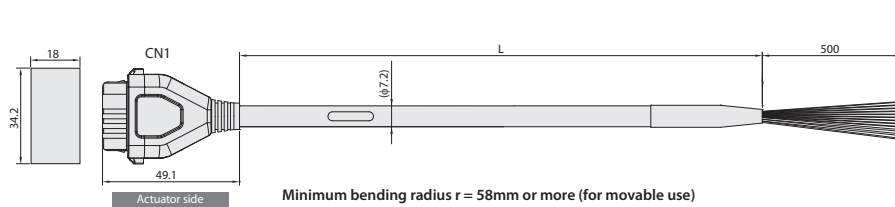

Minimum bending radius $r = 58\text{mm}$ or more (for movable use)
*Only the robot cable is available for this model.

Color	Signal name	Pin No.
Black (AWG18)	0V	A1
Red (AWG18)	24V	B1
Light blue (AWG22) (Reserved) (Note 1)		A2
Orange (AWG26)	IN0	B3
Yellow (AWG26)	IN1	B4
Green (AWG26)	IN2	B5
Pink (AWG26) (Reserved)	OUT0	B6
Blue (AWG26)	OUT0	A3
Purple (AWG26)	OUT1	A4
Gray (AWG26)	OUT2	A5
White (AWG26) (Reserved)		A6
Brown (AWG26)	BKRLS	B2

(Note 1) 24V (control) when split motor and controller power supply specification (TMD2) are selected.

Model **CB-EC2-PWBIO□□□-RB**

*Please indicate the cable length (L) in □□□ (for example, 030 = 3m)

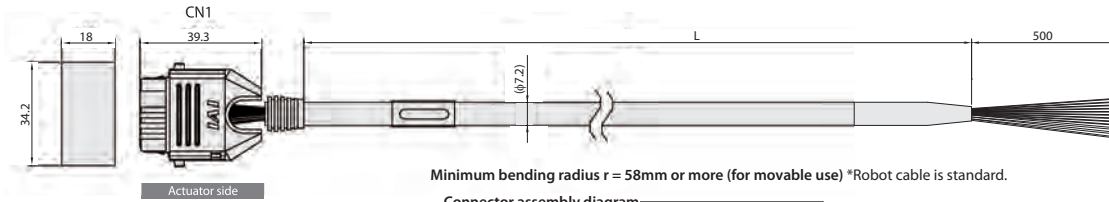

Minimum bending radius $r = 58\text{mm}$ or more (for movable use) *Robot cable is standard.

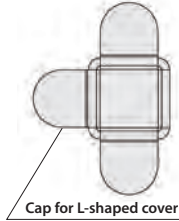
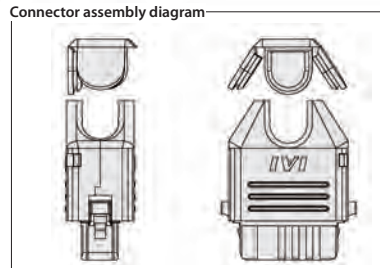

Color	Signal name	Pin No.
Black (AWG18)	0V	A1
Red (AWG18)	24V	B1
Light blue (AWG22) (Reserved) (Note 1)		A2
Orange (AWG26)	IN0	B3
Yellow (AWG26)	IN1	B4
Green (AWG26)	IN2	B5
Pink (AWG26) (Reserved)	OUT0	B6
Blue (AWG26)	OUT0	A3
Purple (AWG26)	OUT1	A4
Gray (AWG26)	OUT2	A5
White (AWG26) (Reserved)		A6
Brown (AWG26)	BKRLS	B2

(Note 1) 24V (control) when split motor and controller power supply specification (TMD2) are selected.

Model **CB-REC-PWBIO□□□-RB**

*Please indicate the cable length (L) in □□□, maximum 10m (for example, 030 = 3m)

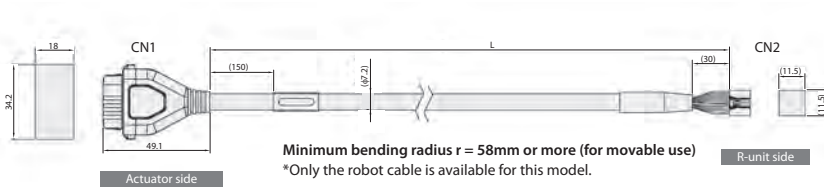

Minimum bending radius $r = 58\text{mm}$ or more (for movable use)
*Only the robot cable is available for this model.

Color	Signal name	Pin No.	Pin No.	Signal name	Color
Black (AWG18)	0V	A1	1	24V (MP)	Red (AWG18)
Red (AWG18)	24V (MP)	B1	12	24V (CP)	Light blue (AWG22)
Light blue (AWG22) (Reserved) (Note 1)	24V (CP)	A2	7	OUT0	Orange (AWG26)
Orange (AWG26)	IN0	B3	8	OUT1	Yellow (AWG26)
Yellow (AWG26)	IN1	B4	9	OUT2	Green (AWG26)
Green (AWG26)	IN2	B5	6	SD+	Pink (AWG26)
Pink (AWG26)	SD+	B6	10	SD-	White (AWG26)
White (AWG26)	SD-	A6	3	INO	Blue (AWG26)
Blue (AWG26)	OUT0	A3	4	IN1	Purple (AWG26)
Purple (AWG26)	OUT1	A4	5	IN2	Gray (AWG26)
Gray (AWG26)	OUT2	A5	11	BKRLS	Brown (AWG26)
Brown (AWG26)	BKRLS	B2	13	FG	Green (AWG26)

Model **CB-REC2-PWBIO□□□-RB**

*Please indicate the cable length (L) in □□□, maximum 10m (for example, 030 = 3m)

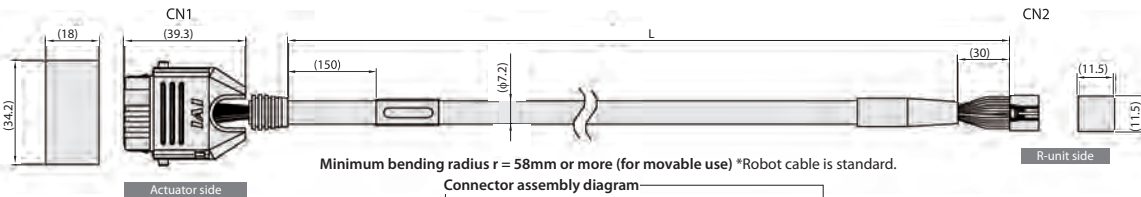

Minimum bending radius $r = 58\text{mm}$ or more (for movable use) *Robot cable is standard.

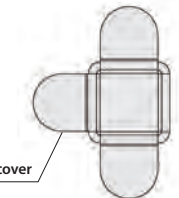
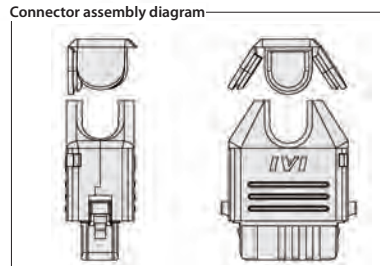

Color	Signal name	Pin No.	Pin No.	Signal name	Color
Black (AWG18)	0V	A1	2	0V	Black (AWG22)
Red (AWG18)	24V (MP)	B1	1	24V (MP)	Red (AWG22)
Light blue (AWG22) (Reserved) (Note 1)	24V (CP)	A2	12	24V (CP)	Light blue (AWG22)
Orange (AWG26)	IN0	B3	7	OUT0	Orange (AWG26)
Yellow (AWG26)	IN1	B4	8	OUT1	Yellow (AWG26)
Green (AWG26)	IN2	B5	9	OUT2	Green (AWG26)
Yellow (AWG26)	SD+	B6	6	SD+	Yellow (AWG26)
Light gray (AWG26)	SD-	A6	10	SD-	Light gray (AWG26)
Blue (AWG26)	OUT0	A3	3	INO	Blue (AWG26)
Purple (AWG26)	OUT1	A4	4	IN1	Purple (AWG26)
Gray (AWG26)	OUT2	A5	5	IN2	Gray (AWG26)
Brown (AWG26)	BKRLS	B2	11	BKRLS	Brown (AWG26)
			13	FG	Green (AWG26)

■ Four-way connector cable

This cable allows the connector direction to be changed to any of 4 directions.

The cable wiring for the connector is the same as that of power I/O cable CB-EC-PWBIO□□□-RB.

Model: CB-EC2-PWBIO□□□-RB

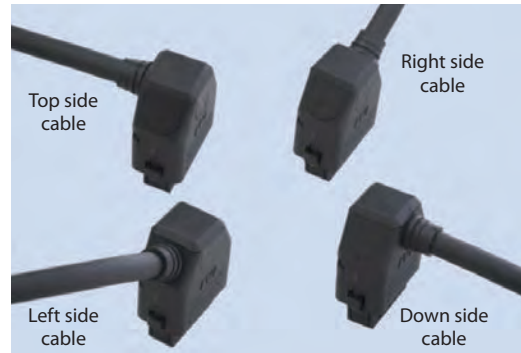

Cable direction can be set to any of 4 directions

- The wiring on the side opposite the connector is left unprepared.
- The cable length may be from 1m to 10m long.
The length can be specified in 1m units.
- Example models are listed below.
 - Cable length 1m → CB-EC2-PWBIO010-RB
 - Cable length 3m → CB-EC2-PWBIO030-RB
 - Cable length 10m → CB-EC2-PWBIO100-RB

Follow the procedure below to assemble the connector in the desired direction.

- (1) Insert while sliding along the groove in the desired direction from the semi-cylindrical curved portion.
- (2) Confirm that the cable has been firmly inserted, and then insert the 2 sides of the lid along the groove.
- (3) Finally, press the remaining side of the lid.

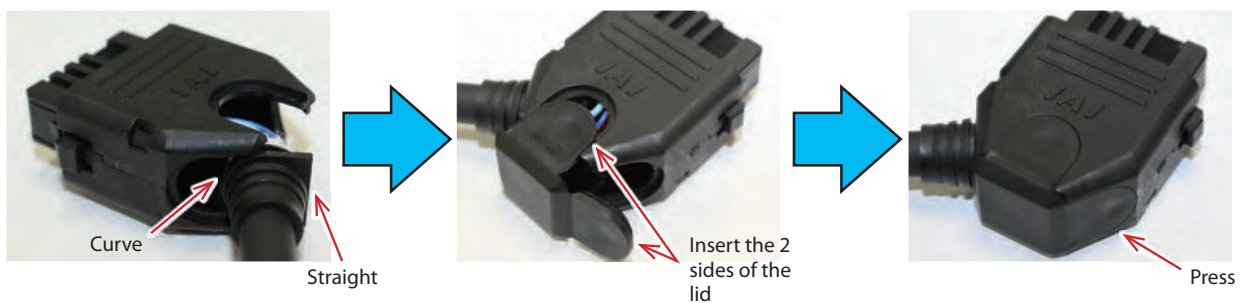

**EC EleCylinder Series
2-Finger Gripper Type
Catalogue No. 1121-E**

The information contained in this catalog
is subject to change without notice for the
purpose of product improvement



IAI Industrieroboter GmbH

Ober der Röth 4

D-65824 Schwalbach / Frankfurt

Germany

Phone: +49-6196-8895-0

Fax: +49-6196-8895-24

E-Mail: info@IAI-automation.com

Internet: IAI-automation.com

IAI America, Inc.

2690 W. 237th Street, Torrance, CA 90505, U.S.A

Phone: +1-310-891-6015, Fax: +1-310-891-0815

IAI (Shanghai) Co., Ltd

Shanghai Jiahua Business Center A8-303, 808,

Hongqiao Rd., Shanghai 200030, China

Phone: +86-21-6448-4753, Fax: +86-21-6448-3992

IAI CORPORATION

577-1 Obane, Shimizu-Ku, Shizuoka, 424-0103 Japan

Phone: +81-543-64-5105, Fax: +81-543-64-5192

IAI Robot (Thailand) Co., Ltd

825 PhairojKijja Tower 12th Floor, Bangna-Trad RD.,

Bangna, Bangna, Bangkok 10260, Thailand

Phone: +66-2-361-4457, Fax: +66-2-361-4456