



TRANSISTORIZED INVERTER  
INSTRUCTION MANUAL

---

HIGH-DUTY BRAKE RESISTOR

**FR-ABR-(H)0.4K to 15K**

Thank you for choosing the Mitsubishi transistorized inverter option unit.

This instruction manual gives handling information and precautions for use of this equipment.

Incorrect handling might cause an unexpected fault. Before using the equipment, please read this manual carefully to use the equipment to its optimum.

Please forward this instruction manual to the end user.

## Safety Instructions

Do not attempt to install, operate, maintain or inspect this product until you have read through this instruction manual and appended documents carefully and can use the equipment correctly.

Do not use this product until you have a full knowledge of the equipment, safety information and instructions.

In this manual, the safety instruction levels are classified into "WARNING" and "CAUTION".



Denotes that incorrect handling may cause hazardous conditions, resulting in death or severe injury.



Denotes that incorrect handling may cause hazardous conditions, resulting in medium or slight injury, or may cause physical damage only.

Note that even the  CAUTION level may lead to a serious consequence under some circumstances. Please follow the instructions of both levels as they are important to personnel safety.

---

### SAFETY INSTRUCTIONS

---

#### 1. Electric Shock Prevention



### WARNING

- Before starting wiring or inspection, switch power off, wait for more than 10 minutes, and check for no residual voltage with a meter etc.
- Any person who is involved in the wiring or inspection of this equipment should be fully competent to do the work.

## 2. Fire Prevention

### CAUTION

- Mount the brake resistor on a non-combustible surface. Installing it directly on or near a combustible surface could cause a fire.
- Use the alarm signal to switch power off. A failure to do so can overheat the brake resistor due to a brake transistor failure etc., causing a fire.

## 3. Injury Prevention

### CAUTION

- Ensure that the cables are connected to the correct terminals. Otherwise, damage, etc. may occur.
- While power is on or for some time after power-off, do not touch the brake resistor as it is hot. Touching it can cause burns.

## 4. Additional Instructions

Also note the following points to prevent an accidental failure, injury, electric shock, etc.:

### (1) Transportation and installation

### CAUTION

- Transport products in a correct manner according to their weights. Not doing so can cause injury.
- Install the product in a place secure enough to withstand its weight according to the instruction manual.

### (2) Usage

### WARNING

- Do not modify the equipment.

### (3) Disposal

### CAUTION

- Dispose of this product as general industrial waste.

### (4) General instructions

Many of the diagrams and drawings in this instruction manual show the inverter without a cover, or partially open. Never run the inverter like this. Always replace the cover and follow the instruction manual when operating the inverter.

## **INSTALLATION INSTRUCTIONS FOR COMPLIANCE WITH UL**

Install the FR-ABR brake resistors as follows:

- The resistor may be mounted horizontally or vertically, depending on a suitable surface location.
- When the resistor is mounted externally to the enclosure housing the inverter, install a solid Type 1 enclosure at least 8 times the volume size of the resistor that incorporates mesh or perforated steel type ventilation openings at each end of the resistor. Note, the vent openings shall not be greater than 10 mm diameter.
- Secure the enclosure to a non-combustible surface only, such as metal or concrete.
- Mount the resistor inside the Type 1 enclosure and wire it in accordance with the NEC for North America installations or any other local codes.

Note, when the resistor and inverter are mounted together within a suitable enclosure, the mesh covering is not required. Please take care that the Inverter unit / resistor internal enclosure ambient does not exceed 50 deg. C.

Enclosure surface presents a possible burn hazard. After installation, the following marking in minimum 3 mm (1/8 in.) sized lettering shall be provided on the enclosure where visible:

**CAUTION : HOT SURFACE. TO REDUCE RISK OF BURN - DO NOT TOUCH.**

# 1. UNPACKING AND CHECKING THE MODEL AND APPLICABLE INVERTERS

Take the brake resistor out of the package and confirm that the product is as you ordered and intact.

The FR-ABR Series brake resistors are a UL Listed Accessory for use only with the following inverter models:

High-Duty Brake Resistor Model		Applicable Inverter Models
200V Class	FR-ABR-0.4K	FR-A520-0.4K(-**), FR-E520-0.4K(C)(-**), FR-E520S-0.4K(-**), FR-E510W-0.4K(-**), FR-A024-0.4K(-**), FR-S520E-0.4K(-**)
	FR-ABR-0.75K	FR-A520-0.75K(-**), FR-E520-0.75K(C)(-**), FR-E520S-0.75K(-**), FR-E510W-0.75K(-**), FR-A024-0.75K(-**), FR-S520E-0.75K(-**)
	FR-ABR-2.2K	FR-A520-1.5K(-**), FR-A520-2.2K(-**), FR-E520-1.5K(C)(-**), FR-E520-2.2K(C)(-**), FR-V520-1.5K(-**), FR-V520-2.2K(-**), FR-A024-1.5K(-**), FR-A024-2.2K(-**), FR-S520E-1.5K(-**), FR-S520E-2.2K(-**)
	FR-ABR-3.7K	FR-A520-3.7K(-**), FR-E520-3.7K(C)(-**), FR-V520-3.7K(-**), FR-A024-3.7K(-**), FR-S520E-3.7K(-**)
	FR-ABR-5.5K	FR-A520-5.5K(-**), FR-E520-5.5K(C)(-**), FR-V520-5.5K(-**)
	FR-ABR-7.5K	FR-A520-7.5K(-**), FR-E520-7.5K(C)(-**), FR-V520-7.5K(-**)
	FR-ABR-11K	FR-V520-11K(-**)
	FR-ABR-15K	FR-V520-15K(-**)

Note : \*\* indicates alpha numeric combination.

High-Duty Brake Resistor Model		Applicable Inverter Models
<b>400V Class</b>	FR-ABR-H0.4K	FR-A540-0.4K(-**) FR-E540-0.4K(C)(-**) FR-A044-0.4K(-**)
	FR-ABR-H0.75K	FR-A540-0.75K(-**) FR-E540-0.75K(C)(-**) FR-A044-0.75K(-**)
	FR-ABR-H1.5K	FR-A540-1.5K(-**) FR-E540-1.5K(C)(-**) FR-V540-1.5K(-**) FR-A044-1.5K(-**)
	FR-ABR-H2.2K	FR-A540-2.2K(-**) FR-E540-2.2K(C)(-**) FR-V540-2.2K(-**) FR-A044-2.2K(-**)
	FR-ABR-H3.7K	FR-A540-3.7K(-**) FR-E540-3.7K(C)(-**) FR-V540-3.7K(-**) FR-A044-3.7K(-**)
	FR-ABR-H5.5K	FR-A540-5.5K(-**) FR-E540-5.5K(C)(-**) FR-V540-5.5K(-**)
	FR-ABR-H7.5K	FR-A540-7.5K(-**) FR-E540-7.5K(C)(-**) FR-V540-7.5K(-**)
	FR-ABR-H11K	FR-V540-11K(-**)
	FR-ABR-H15K	FR-V540-15K(-**)

Note : \*\* indicates alpha numeric combination.

## 2. GENERAL INSTRUCTIONS FOR INSTALLATION

### (If you need to meet UL requirement refer to page A-3)

- Never mount the resistor near wood, paper or any other combustible material. Doing so can cause a fire.
- To prevent burns, do not install the resistor in a place where it is readily accessible. If it is easily accessible, mount in a well-ventilated enclosure (e.g. punched metal), suitable for the environment.
- Mount the resistor carefully so that the leads do not come from the top of the resistor.
- Avoid contact with the resistor when running the leads of the resistor and any other wiring.

Install the resistor in a place with good heat dissipation. The reason for this is that the surface temperature of the resistor may exceed 360°C in an operation pattern where the resistor is used frequently.

To increase the heat dissipation effect, we recommend you to install the resistor on a metal surface outside the enclosure.

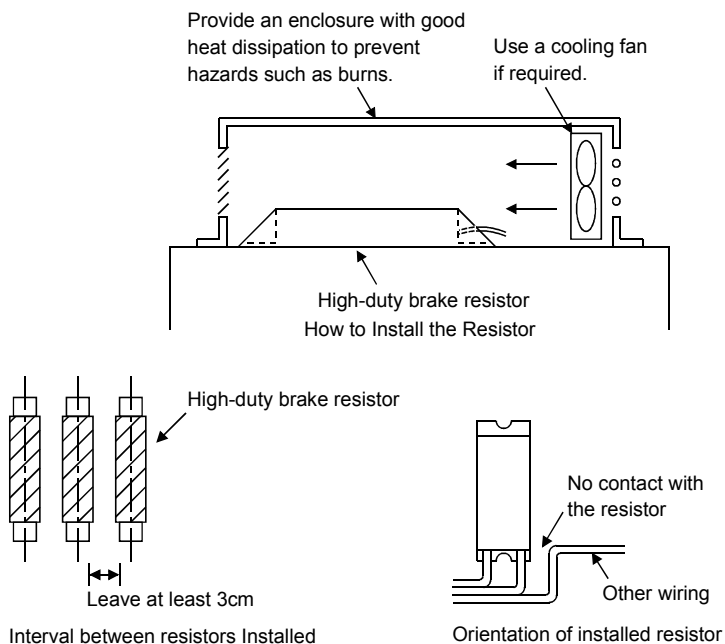

### 3. INSTRUCTIONS FOR WIRING

When the regenerative brake transistor is damaged, the wiring sequence as shown in the following diagrams is recommended to prevent overheating and burnout of the brake resistor.

<Example 1>

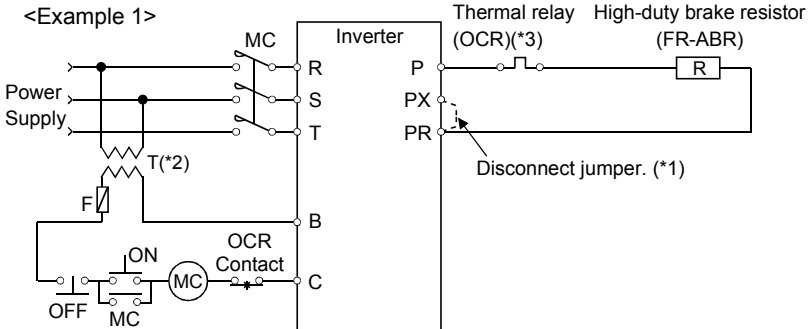

<Example 2>

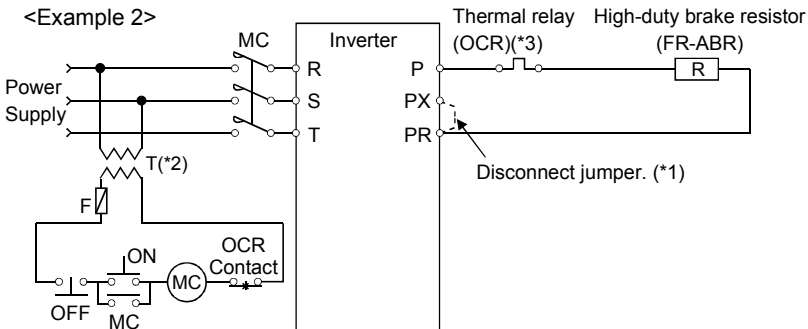

- Remove the link from across the PR-PX terminals of the inverter. (\*1) This disables (switches off) the built-in brake resistor. (Refer to the instruction manual of the inverter for details.)

Note that the built-in brake resistor need not be removed. The leads of the built-in brake resistor need not be disconnected from the terminals.

\*1 When you use the FR-E500 series inverter, the FR-V500 series-7.5K or more inverter and the FR-A500 series-11K or more inverter, you need not remove the jumper since that inverter does not have the PX terminals. (Refer to the instruction manual of the inverter.)

\*2 For the 400V class power supply, install a voltage-reducing transformer.

\*3 When using the (H)11K or 15K, install a thermal relay.

Refer to the following table for the thermal relay model number and to the following diagram for connection.

Capacity	Thermal relay (OCR)	Contact Rating
11K/15K	TH-N20CXHZ-11A	AC110V 5A, AC220V 2A (AC11 class)
H11K/H15K	TH-N20CXHZ-6.6A	DC110V 0.5A, DC220V 0.25A (DC11 class)

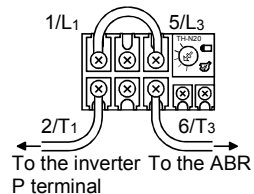



- Connect the leads of the high-duty brake resistor to the P and PR terminals of the inverter. When using the 15K inverter, connect two high-duty brake resistors ( $18\Omega$ ) in parallel. When using the H15K inverter, connect two high-duty brake resistors ( $18\Omega$ ) in series using the terminal block enclosed.

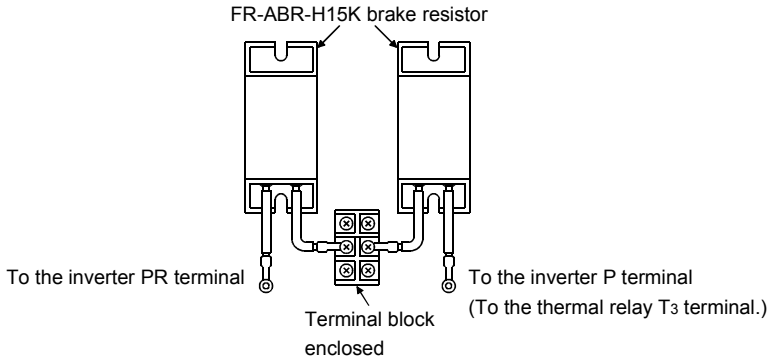

- If the resistor lead length is not sufficient to reach the inverter terminals, additional lead wire, sized as noted below and not exceeding 5 m in length, may be used. Installation shall be in accordance with the North American or Canadian Electrical Code.

### CAUTION

1. **The high-duty brake resistor cannot be used with a brake unit, high power factor converter, power return converter, built-in brake etc.**
2. **Twist the leads of the high-duty brake resistor when increasing their length 2m or more. (The wire size used should be minimum 14 AWG ( $2.1\text{mm}^2$ )).**  
**Note that even the twisted leads cannot be made longer than 5m. Doing so can cause an inverter failure.**
3. **The FR-ABR-(H)11K, 15K can not be used with the FR-A500 series.**

## 4. INSTRUCTIONS FOR USE

- Setting of inverter parameters
  - 1) The parameter setting method varies with the inverter series. Refer to the instruction manual of the inverter.

## 5. SPECIFICATIONS

### 1) Permissible duty and torque

Item	FR-ABR-□ (200V Class)							FR-ABR-H□ (400V Class)								
	0.4K	0.75K	2.2K	3.7K	5.5K	7.5K	11K	15K	0.4K	0.75K	1.5K	2.2K	3.7K	5.5K	7.5K	11K
Braking torque	150% 5s		100% 5s					100% 5s								
Permissible duty*	10%ED						6%ED		10%ED						6%ED	

\* The permissible duty represents the braking capability including the motor loss. The actual duty of the resistor is slightly lower than that.

## 6. OUTLINE DIMENSIONS

FR-ABR-0.4K to 7.5K, H0.4K to H7.5K

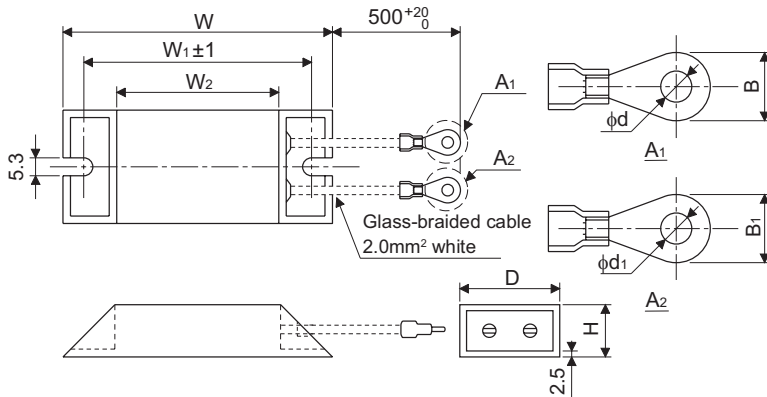

Brake Resistor Model		Dimensions (Unit: mm)					Resistance (Ω)	Crimping Terminal (Unit: mm)			
		W	W <sub>1</sub>	W <sub>2</sub>	D	H		A <sub>1</sub>		A <sub>2</sub>	
								B	d	B <sub>1</sub>	d <sub>1</sub>
200V Class	FR-ABR-0.4K	140	125	100	40	21	7.0	4.3	7.0	4.3	
	FR-ABR-0.75K	215	200	175	40	21					
	FR-ABR-2.2K*1	240	225	200	50	26					
	FR-ABR-3.7K	215	200	175	61	33	9.5	5.3	9.5	5.3	
	FR-ABR-5.5K	335	320	295	61	33					
	FR-ABR-7.5K	400	385	360	80	40					
400V Class	FR-ABR-H0.4K	115	100	75	40	21	7.0	4.3	7.0	4.3	
	FR-ABR-H0.75K	140	125	100	40	21					
	FR-ABR-H1.5K	215	200	175	40	21					
	FR-ABR-H2.2K	240	225	200	50	26	9.5	5.3	9.5	5.3	
	FR-ABR-H3.7K	215	200	175	61	33					
	FR-ABR-H5.5K	335	320	295	61	33					
FR-ABR-H7.5K	400	385	360	80	40	75					

\*1 Used for 1.5K and 2.2K.

FR-ABR-11K to 15K, H11K, H15K

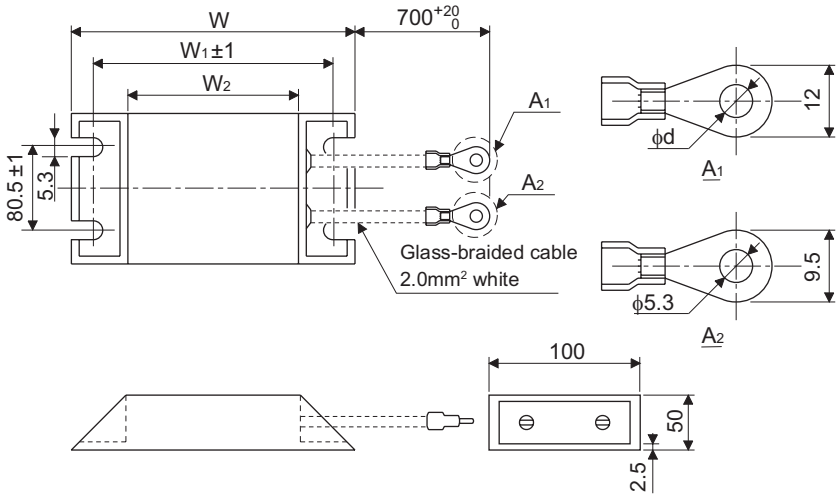

Brake Resistor Model		Dimensions (Unit: mm)			Resistance (Ω)	Cramping Terminal (Unit: mm)
		W	W <sub>1</sub>	W <sub>2</sub>		d
200V Class	FR-ABR-11K	400	385	360	13	6.4
	FR-ABR-15K*1	300	285	260	18	8.4
400V Class	FR-ABR-H11K	400	385	360	52	6.4
	FR-ABR-H15K*2	300	285	260	18	8.4

\*1 For the 15K, connect two resistors (18Ω) in parallel.

\*2 For the H15K, connect two resistors (18Ω) in series.

# 7. BRAKING CAPABILITIES

## 7.1 Continuous Permissible Power

200V Class			400V Class		
Model	Resistance	Continuous Permissible Power	Model	Resistance	Continuous Permissible Power
FR-ABR-0.4K	200Ω	60W	FR-ABR-H0.4K	1200Ω	45W
FR-ABR-0.75K	100Ω	80W	FR-ABR-H0.75K	700Ω	75W
FR-ABR-2.2K	60Ω	120W	FR-ABR-H1.5K	350Ω	115W
FR-ABR-3.7K	40Ω	155W	FR-ABR-H2.2K	250Ω	120W
FR-ABR-5.5K	25Ω	185W	FR-ABR-H3.7K	150Ω	155W
FR-ABR-7.5K	20Ω	340W	FR-ABR-H5.5K	110Ω	185W
FR-ABR-11K	13Ω	560W	FR-ABR-H7.5K	75Ω	340W
FR-ABR-15K	9Ω*1	805W	FR-ABR-H11K	52Ω	530W
			FR-ABR-H15K	36Ω*2	870W

\*1 When two resistors are connected in series

\*2 When two resistors are connected in parallel

## 7.2 Short-Duration Permissible Power per Braking

- 200V Class

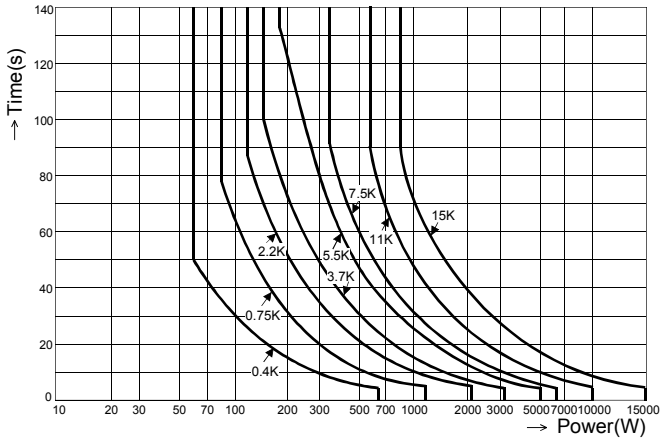

- 400V Class

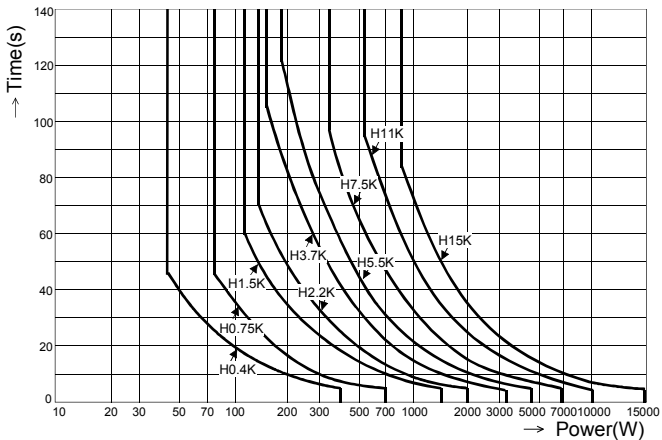

## REVISIONS

\*The manual number is given on the bottom left of the back cover.

Print Date	*Manual Number	Revision				
Nov., 1998	IB(NA)-66891-A	First edition				
Mar., 2001	IB(NA)-66891-B	<table border="1"><tr><td>Partial Additions</td></tr><tr><td><ul style="list-style-type: none"><li>• Applicable inverters</li><li>• Instructions for wiring</li></ul></td></tr></table>	Partial Additions	<ul style="list-style-type: none"><li>• Applicable inverters</li><li>• Instructions for wiring</li></ul>		
Partial Additions						
<ul style="list-style-type: none"><li>• Applicable inverters</li><li>• Instructions for wiring</li></ul>						
Apr., 2002	IB(NA)-66891-C	<table border="1"><tr><td>Additions</td></tr><tr><td>FR-ABR-11K, FR-ABR-15K</td></tr></table>	Additions	FR-ABR-11K, FR-ABR-15K		
Additions						
FR-ABR-11K, FR-ABR-15K						
Aug., 2002	IB(NA)-66891-D	<table border="1"><tr><td>Additions</td></tr><tr><td>FR-ABR-H11K, FR-ABR-H15K</td></tr><tr><td>Partial Addition</td></tr><tr><td>Instructions for wiring</td></tr></table>	Additions	FR-ABR-H11K, FR-ABR-H15K	Partial Addition	Instructions for wiring
Additions						
FR-ABR-H11K, FR-ABR-H15K						
Partial Addition						
Instructions for wiring						
Oct., 2003	IB(NA)-66891-E	<table border="1"><tr><td>Additions</td></tr><tr><td>UL compliance</td></tr></table>	Additions	UL compliance		
Additions						
UL compliance						
Mar., 2004	IB(NA)-66891-F	<table border="1"><tr><td>Modifications</td></tr><tr><td>OUTLINE DIMENTIONS, OUTLINE DIMENSION DRAWINGS</td></tr></table>	Modifications	OUTLINE DIMENTIONS, OUTLINE DIMENSION DRAWINGS		
Modifications						
OUTLINE DIMENTIONS, OUTLINE DIMENSION DRAWINGS						

**HEADQUARTERS**

**MITSUBISHI ELECTRIC EUROPE**  
EUROPE B.V.  
German Branch  
Gothaer Straße 8  
**D-40880 Ratingen**  
Phone: +49 (0)2102 486-0  
Fax: +49 (0)2102 486-1120  
e mail: megfamail@meg.mee.com

**MITSUBISHI ELECTRIC FRANCE**  
EUROPE B.V.  
French Branch  
25, Boulevard des Bouvets  
**F-92741 Nanterre Cedex**  
Phone: +33 1 55 68 55 68  
Fax: +33 1 55 68 56 85  
e mail: factory.automation@fra.mee.com

**MITSUBISHI ELECTRIC IRELAND**  
EUROPE B.V.  
Irish Branch  
Westgate Business Park, Ballymount  
**IRL-Dublin 24**  
Phone: +353 (0) 1 / 419 88 00  
Fax: +353 (0) 1 / 419 88 90  
e mail: sales.info@meir.mee.com

**MITSUBISHI ELECTRIC ITALY**  
EUROPE B.V.  
Italian Branch  
Via Paracelso 12  
**I-20041 Agrate Brianza (MI)**  
Phone: +39 039 60 53 1  
Fax: +39 039 60 53 312  
e mail: factory.automation@it.mee.com

**MITSUBISHI ELECTRIC SPAIN**  
EUROPE B.V.  
Spanish Branch  
Carretera de Rubí 76-80  
**E-08190 Sant Cugat del Vallés**  
Phone: +34 9 3 565 3131  
Fax: +34 9 3 589 2948  
e mail: industrial@sp.mee.com

**MITSUBISHI ELECTRIC UK**  
EUROPE B.V.  
UK Branch  
Travellers Lane  
**GB-Hatfield Herts. AL10 8 XB**  
Phone: +44 (0) 1707 / 27 61 00  
Fax: +44 (0) 1707 / 27 86 95  
e mail: automation@meuk.mee.com

**MITSUBISHI ELECTRIC CORPORATION JAPAN**  
Office Tower "Z" 14 F  
8-12,1 chome, Harumi Chuo-Ku  
**Tokyo 104-6212**  
Phone: +81 3 622 160 60  
Fax: +81 3 622 160 75

**MITSUBISHI ELECTRIC AUTOMATION USA**  
500 Corporate Woods Parkway  
**Vernon Hills, IL 60061**  
Phone: +1 847 478 21 00  
Fax: +1 847 478 22 83

**EUROPEAN REPRESENTATIVES**

**GEVA AUSTRIA**  
Wiener Straße 89  
**AT-2500 Baden**  
Phone: +43 (0)2252 / 85 55 20  
Fax: +43 (0)2252 / 488 60  
e mail: office@geva.at

**TEHNIKON BELARUS**  
Oktjabskaya 16/5, Ap 704  
**BY-220030 Minsk**  
Phone: +375 (0)17 / 2104626  
Fax: +375 (0)17 / 2275830  
e mail: tehnikon@belsonet.net

**Getronics b.v. BELGIUM**  
Control Systems  
Pontbeeklaan 43  
**BE-1731 Asse-Zellik**  
Phone: +32 (0)2 / 467 17 51  
Fax: +32 (0)2 / 467 17 45  
e mail: infoautomation@getronics.com

**TELECON CO. BULGARIA**  
4, A. Ljapchev Blvd.  
**BG-1756 Sofia**  
Phone: +359 (0)2 / 97 44 058  
Fax: +359 (0)2 / 97 44 061  
e mail: —

**INEA CR d.o.o. CROATIA**  
Losinjska 4 a  
**HR-10000 Zagreb**  
Phone: +385 (0) 1 / 36 940-01  
Fax: +385 (0) 1 / 36 940-03  
e mail: inea@inea.hr

**AutoCont CZECH REPUBLIC**  
Control Systems s.r.o.  
Nemocnicni 12  
**CZ-70200 Ostrava 2**  
Phone: +420 59 / 6152 111  
Fax: +420 59 / 6152 562  
e mail: consys@autocont.cz

**louis poulsen DENMARK**  
industri & automation  
Geminivej 32  
**DK-2670 Greve**  
Phone: +45 (0)43 / 95 95 95  
Fax: +45 (0)43 / 95 95 91  
e mail: lpia@lpmail.com

**UTU Elektrotehnika AS ESTONIA**  
Pärnu mnt.160i  
**EE-10621 Tallinn**  
Phone: +372 (0)6 / 51 72 80  
Fax: +372 (0)6 / 51 72 88  
e mail: utu@utu.ee

**UTU POWEL OY FINLAND**  
Box 236  
**FIN-28101 Pori**  
Phone: +358 (0)2 / 550 800  
Fax: +358 (0)2 / 550 8841  
e mail: tehoelektronikka@urhotuominen.fi

**UTECO A.B.E.E. GREECE**  
5, Mavrogenous Str.  
**GR-18542 Piraeus**  
Phone: +302 (0)10 / 42 10 050  
Fax: +302 (0)10 / 42 12 033  
e mail: uteco@uteco.gr

**Meltrade Automatika Kft. HUNGARY**  
55, Harmat St.  
**HU-1105 Budapest**  
Phone: +36 (0)1 / 2605 602  
Fax: +36 (0)1 / 2605 602  
e mail: office@meltrade.hu

**SIA POWEL LATVIA**  
Lienes iela 28  
**LV-1009 Riga**  
Phone: +371 784 2280  
Fax: +371 784 2281  
e mail: utu@utu.lv

**UAB UTU POWEL LITHUANIA**  
Savanoriu Pr. 187  
**LT-2053 Vilnius**  
Phone: +370 (0)52323-101  
Fax: +370 (0)52322-980  
e mail: powel@utu.lt

**EUROPEAN REPRESENTATIVES**

**Intehsis Srl MOLDOVA**  
Cuza-Voda 36/1-81  
**MD-2061 Chisinau**  
Phone: +373 (0)2 / 562 263  
Fax: +373 (0)2 / 562 263  
e mail: intehsis@mdl.net

**Getronics b.v. NETHERLANDS**  
Control Systems  
Donauweg 2 B  
**NL-1043 AJ Amsterdam**  
Phone: +31 (0)20 / 587 6700  
Fax: +31 (0)20 / 587 6839  
e mail: info.gia@getronics.com

**Motion Control NETHERLANDS**  
Automation b.v.  
Markenweg 5  
**NL-7051 HS Varsseveld**  
Phone: +31 (0)315 / 257 260  
Fax: +31 (0)315 / 257 269  
e mail: —

**Beijer Electronics AS NORWAY**  
Teglverksveien 1  
**NO-3002 Drammen**  
Phone: +47 (0)32 / 24 30 00  
Fax: +47 (0)32 / 84 85 77  
e mail: info@beijer.no

**MPL Technology Sp. z o.o. POLAND**  
ul. Sliczna 36  
**PL-31-444 Kraków**  
Phone: +48 (0)12 / 632 28 85  
Fax: +48 (0)12 / 632 47 82  
e mail: krakow@mpl.pl

**Sirius Trading & Services srl ROMANIA**  
Str. Biharia Nr. 67-77  
**RO-013981 Bucuresti 1**  
Phone: +40 (0) 21 / 201 1146  
Fax: +40 (0) 21 / 201 1148  
e mail: sirius@siriustrading.ro

**INEA SR d.o.o. SERBIA AND MONTENEGRO**  
Karadjordjeva 12/260  
**SCG-113000 Smederevo**  
Phone: +381 (0)26/ 617 - 163  
Fax: +381 (0)26/ 617 - 163  
e mail: inea\_sr@verat.net

**ACP Autocomp a.s. SLOVAKIA**  
Chalupkova 7  
**SK-81109 Bratislava**  
Phone: +421 (02)5292-2254  
Fax: +421 (02)5292-2248  
e mail: info@acp-autocomp.sk

**INEA d.o.o. SLOVENIA**  
Stegne 11  
**SI-1000 Ljubljana**  
Phone: +386 (0)1 513 8100  
Fax: +386 (0)1 513 8170  
e mail: inea@inea.si

**Beijer Electronics AB SWEDEN**  
Box 426  
**S-20124 Malmö**  
Phone: +46 (0)40 / 35 86 00  
Fax: +46 (0)40 / 35 86 02  
e mail: info@beijer.de

**ECONOTEC AG SWITZERLAND**  
Postfach 282  
**CH-8309 Nürensdorf**  
Phone: +41 (0)1 / 838 48 11  
Fax: +41 (0)1 / 838 48 12  
e mail: info@econotec.ch

**GTS TURKEY**  
Darülaceze Cad. No. 43A KAT: 2  
**TR-80270 Okmeydani-Istanbul**  
Phone: +90 (0)212 / 320 1640  
Fax: +90 (0)212 / 320 1649  
e mail: gts@turk.net

**CSC Automation UKRAINE**  
15, M. Raskova St., Fl. 10, Off. 1010  
**UA-02002 Kiev**  
Phone: +380 (0)44 / 238 83 16  
Fax: +380 (0)44 / 238 83 17  
e mail: csc-a@csc-a.kiev.ua

**EURASIAN REPRESENTATIVES**

**Avtomatika Sever Ltd. RUSSIA**  
Lva Tolstogo St. 7, Off. 311  
**RU-197376 St Petersburg**  
Phone: +7 812 / 11 83 238  
Fax: +7 812 / 11 83 239  
e mail: as@avtsev.spb.ru

**CONSYS RUSSIA**  
Promyshlennaya St. 42  
**RU-198099 St Petersburg**  
Phone: +7 812 / 325 36 53  
Fax: +7 812 / 325 36 53  
e mail: consys@consys.spb.ru

**ELEKTROSTYLE RUSSIA**  
Poslannikov Per., 9, Str.1  
**RU-107005 Moscow**  
Phone: +7 095 / 542-4323  
Fax: +7 095 / 956-7526  
e mail: info@estl.ru

**ELEKTROSTYLE RUSSIA**  
Krasnij Prospekt 220-1, Office 312  
**RU-630049 Novosibirsk**  
Phone: +7 3832 / 10 66 18  
Fax: +7 3832 / 10 66 26  
e mail: elo@elektrostyle.ru

**ICOS RUSSIA**  
Ryazanskij Prospekt, 8A, Office 100  
**RU-109428 Moscow**  
Phone: +7 095 / 232 0207  
Fax: +7 095 / 232 0327  
e mail: mail@icos.ru

**SMENA RUSSIA**  
Polzunova 7  
**RU-630051 Novosibirsk**  
Phone: +7 095 / 416 4321  
Fax: +7 095 / 416 4321  
e mail: smena-nsk@yandex.ru

**STC Drive Technique RUSSIA**  
Poslannikov per., 9, str.1  
**RU-107005 Moscow**  
Phone: +7 095 / 786 21 00  
Fax: +7 095 / 786 21 01  
e mail: info@privod.ru

**MIDDLE EAST REPRESENTATIVE**

**SHERF Motion Techn. Ltd ISRAEL**  
Rehov Hamerkava 19  
**IL-58851 Holon**  
Phone: +972 (0)3 / 559 54 62  
Fax: +972 (0)3 / 556 01 82  
e mail: —

**AFRICAN REPRESENTATIVE**

**CBI Ltd SOUTH AFRICA**  
Private Bag 2016  
**ZA-1600 Isando**  
Phone: +27 (0)11 / 928 2000  
Fax: +27 (0)11 / 392 2354  
e mail: cbi@cbi.co.za