

W 9-2: compact and diverse – the complete range

 Photoelectric proximity switches, BGS

 Photoelectric proximity switches, energetic

 Photoelectric proximity switches in V version



Depending on the task, the most suitable sensor can be selected from the W 9-2 series.

Overview of the sensors:

WT 9-2, with adjustable scanning distance of up to 250 mm and background suppression,

WT 9-2, energetic,

max. scanning distance 450 mm,

WT 9-2, V model,

max. scanning distance 20 mm,

WL 9-2, basic model,

max. scanning range 4 m,

WL 9-2, teach-in model,

max. scanning range 4 m,

WL 9-2, focus,

max. scanning range 0.4 m.

The W 9-2 series is as varied as the tasks in automation.

The standardized, compact housing design makes it possible to use high-performance sensors that operate reliably even in cramped mounting conditions.

All W 9-2 models have red light transmitters as standard. The sensor can be aligned on the object quickly and precisely using the visible light spot.

In models with teach-in function, the sensor adapts its sensitivity to the existing operating conditions automatically at the push of a button.

Thanks to this great variety of models, there are numerous applications in the main branches they are designed for:

- Storage and handling engineering
- The packaging industry
- The electronics industry
- Elevator construction.

 Photoelectric reflex switches



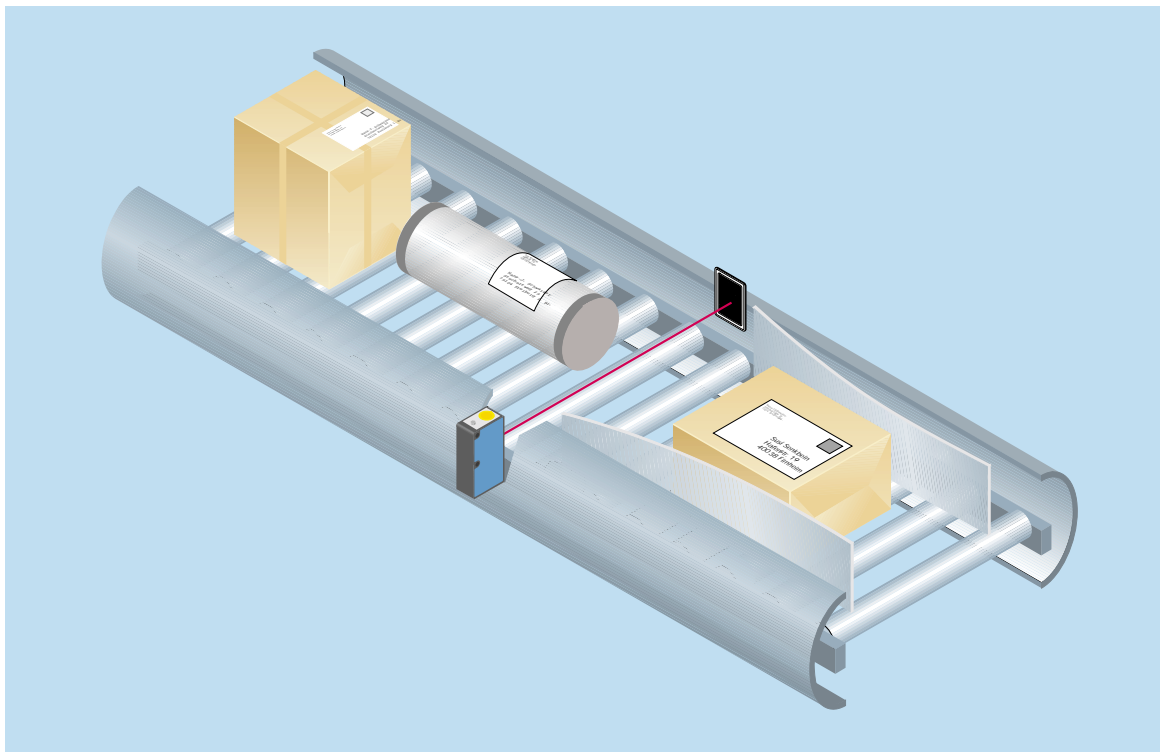

◀ W 9-2 used in storage and conveying; may be used anywhere, fail-safe, compact.

▼ W 9-2 used in the electronics industry; precise detection, short response time.

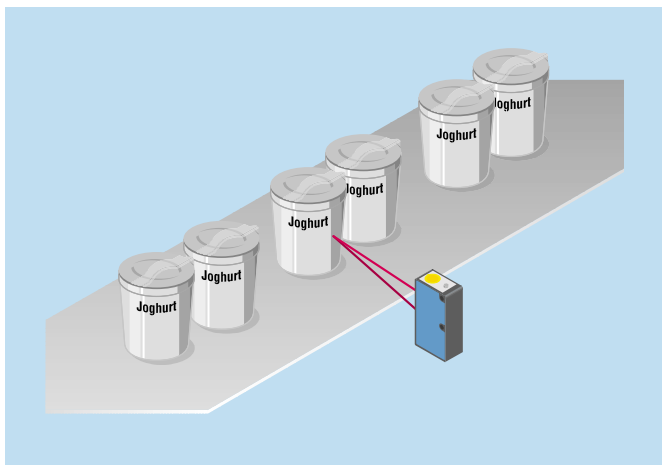

▲ W 9-2 used in the packaging industry; high availability, simple operation.

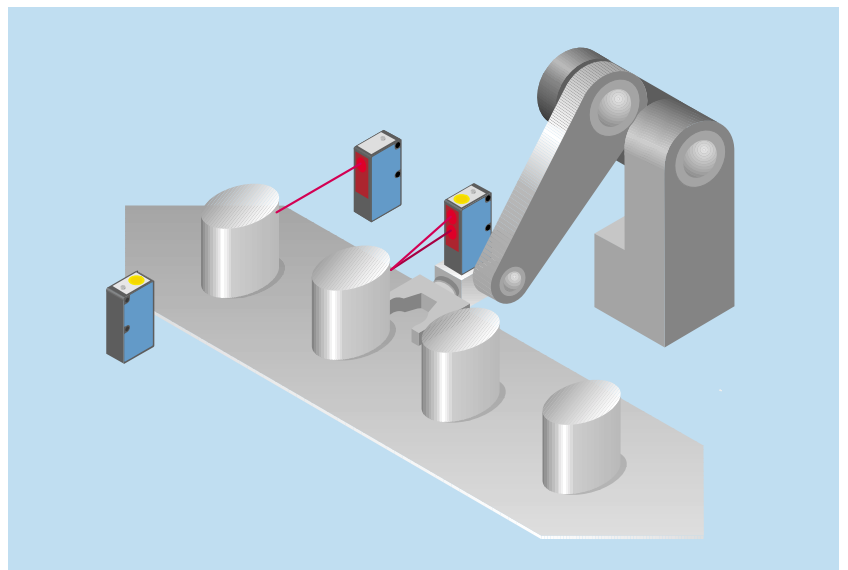
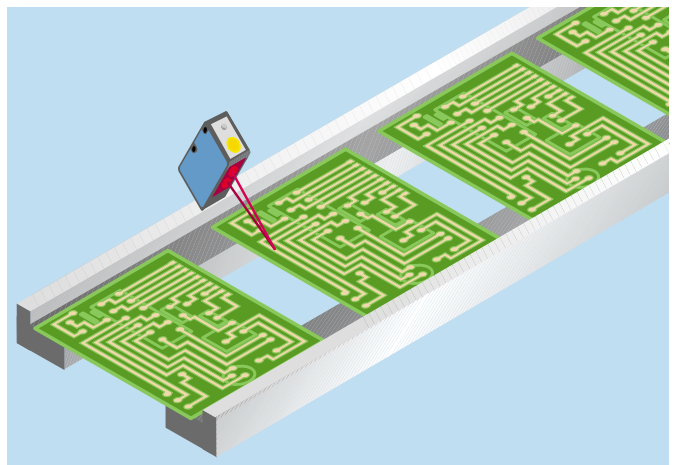

► W 9-2 used in handling; space-saving structure, a range of versions to suit individual tasks.

Scanning distance
 30...250 mm
Photoelectric proximity switches

- LED light source, visible red light
- Background suppression
- Adjustable scanning distance
- Switching frequency 1500/s
- Outputs short-circuit protected

Dimensional drawing

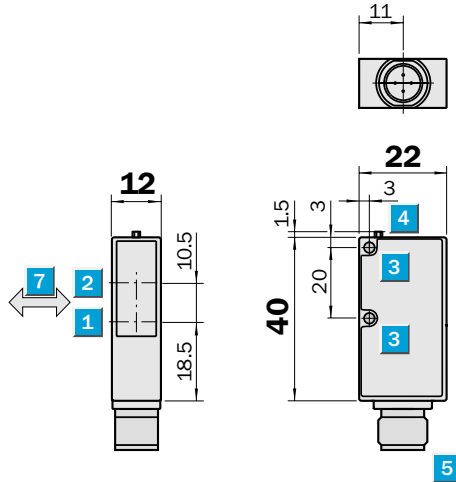

Adjustments possible

WT 9-2P 130	WT 9-2N 130
WT 9-2P 330	WT 9-2N 430
WT 9-2P 430	
WT 9-2P 630	

- 1** Centre of optical axis, sender
- 2** Centre of optical axis, receiver
- 3** Mounting hole \varnothing 3.2 mm
- 4** LED signal strength indicator
- 5** Plug M 12 or M 8, 4 pin,
2 m connection cable or
120 mm cable with plug M 12, 4 pin
- 6** Scanning distance adjustment
- 7** Standard direction of the material to be scanned

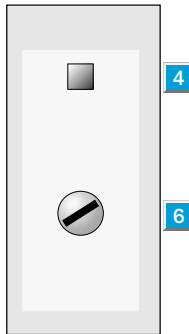

Connection types

WT 9-2P 130	WT 9-2P 330	WT 9-2P 430	WT 9-2P 630
WT 9-2N 130		WT 9-2N 430	

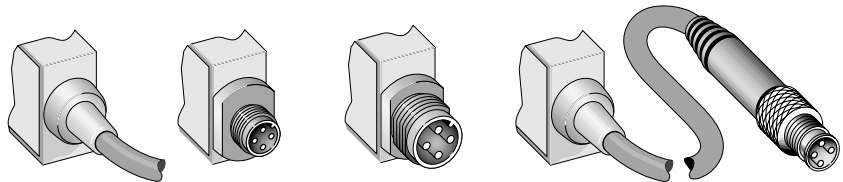

Accessories	page
Cable receptacles	496
Mounting brackets	510

4 x 0.14 mm ²	4-pin, M 8	4-pin, M 12	4-pin, M 12 with 120 mm cable
--------------------------	------------	-------------	-------------------------------

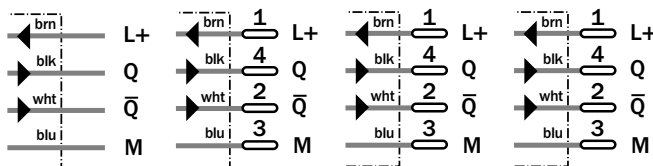

Technical data		WT 9-2	P 130	P 330	P 430	P 630	N 130	N 430				
Scanning distance adjustable¹⁾	30...250 mm											
Scanning range	5...250 mm											
Supply voltage V_S²⁾	10...30 V DC											
Ripple ³⁾	$\leq 5 V_{SS}$											
Current consumption ⁴⁾	≤ 40 mA											
Light source	LED, visible red light ⁵⁾											
Light spot size	15 x 15 mm at 200 mm											
Switching outputs Q and \bar{Q}	PNP											
	NPN											
Signal voltage HIGH	$V_S - 2.9$ V											
	V_S											
Signal voltage LOW ⁶⁾	Approx. 0 V											
	≤ 1.5 V											
Output current I_A max.	≤ 100 mA											
Response time⁷⁾	≤ 333 μ s											
Switching frequency max.⁸⁾	1500/s											
Connection types	Connection cable, 2 m											
	Cable, 120 mm, with plug M 12, 4-pin											
	Plug M 12, 4-pin											
	Plug M 8, 4-pin											
VDE protection class⁹⁾												
Enclosure rating	IP 67											
Circuit protection¹⁰⁾	A, B, C											
Ambient temperature T_A¹¹⁾	Operation - 40...+ 60 °C											
	Storage - 40...+ 75 °C											
Weight												
with connection cable 2 m/120 mm	Approx. 80 g											
with equipment plug M 12/M 8, 4-pin	Approx. 20 g											

- | | | | |
|---|--|------------------------------|---|
| 1) Object with 90 % remission (referred to standard white DIN 5033) | 4) Without load | 7) With resistive load | 10) A = supply connections reverse polarity protected |
| 2) Limit values | 5) Average service life at room temperature 100,000 h at $T_A = + 25$ °C | 8) With light/dark ratio 1:1 | B = outputs short-circuit protected |
| 3) Must be within V_S tolerances | 6) At $T_A = + 25$ °C and 100 mA output current | 9) Reference voltage 50 V | C = interference suppression |
| | | | 11) Do not bend below 0 °C |

Scanning distance

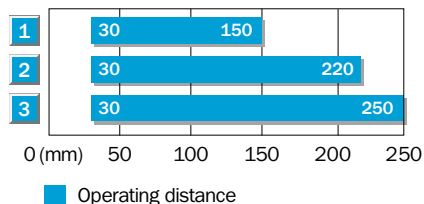

- | | |
|---|--|
| 1 | Scanning distance on black, 6 % remission |
| 2 | Scanning distance on gray, 18 % remission |
| 3 | Scanning distance on white, 90 % remission |

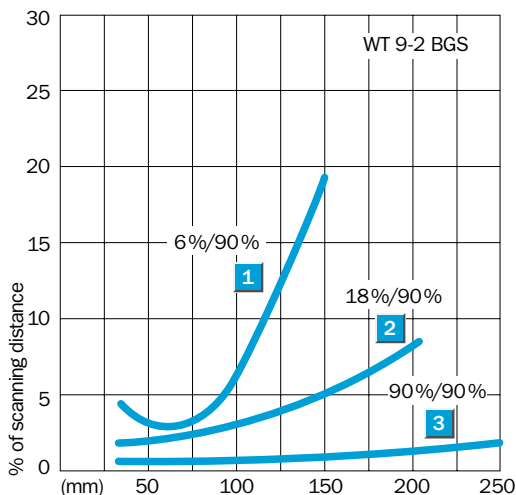

Order information

Type	Part no.
WT 9-2P 130	1 018 293
WT 9-2P 330	1 019 026
WT 9-2P 430	1 018 295
WT 9-2P 630	1 019 272
WT 9-2N 130	1 018 294
WT 9-2N 430	1 018 296

Switches in V version on request.

Scanning distance
10...450 mm
Photoelectric proximity switches

- Red-light sender LED as alignment aid
- Adjustable scanning distance
- Switching frequency 800/s
- Outputs short-circuit protected
- Teach-in

Dimensional drawing

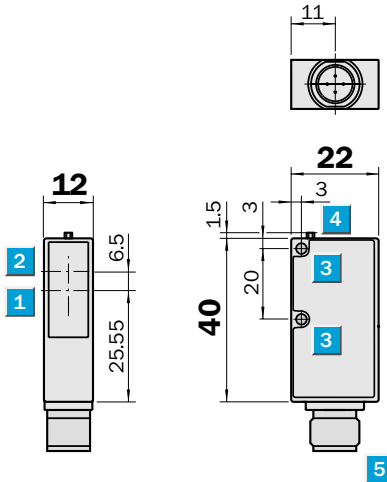

Adjustments possible

WT 9-2P 151	WT 9-2N 151
WT 9-2P 351	WT 9-2N 451
WT 9-2P 451	
WT 9-2P 651	

- 1** Centre of optical axis, receiver
- 2** Centre of optical axis, sender
- 3** Mounting hole \varnothing 3.2 mm
- 4** LED signal strength indicator
- 5** Plug M 12 or M 8, 4 pin, 2 m connection cable or 120 mm cable with plug M 12, 4 pin
- 6** Scanning distance adjustment with teach-in

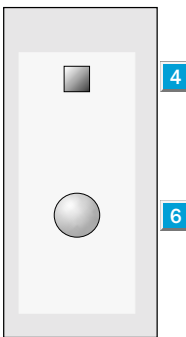

Connection types

WT 9-2P 151	WT 9-2P 351	WT 9-2P 451	WT 9-2P 651
WT 9-2N 151		WT 9-2N 451	

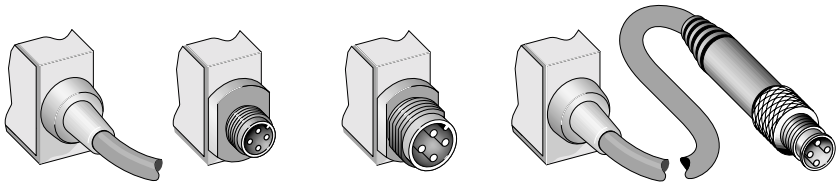

4 x 0.14 mm ²	4-pin, M 8	4-pin, M 12	4-pin, M 12 with 120 mm cable
--------------------------	------------	-------------	-------------------------------

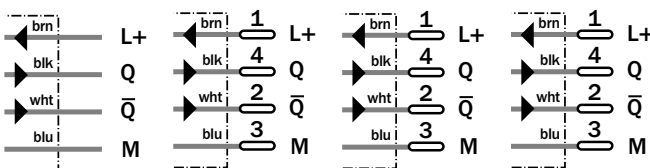

Accessories	page
Cable receptacles	496
Mounting brackets	510
Reflectors	520



Technical data		WT 9-2	P 151	P 351	P 451	P 651	N 151	N 451				
Scanning distance adjustable¹⁾	10...450 mm											
Supply voltage V_S²⁾	10...30 V DC											
Ripple ³⁾	$\leq 5 V_{SS}$											
Current consumption ⁴⁾	≤ 30 mA											
Light source	LED, visible red light ⁵⁾											
Light spot size	80 x 80 mm at 500 mm											
Switching outputs Q and \bar{Q}	PNP											
	NPN											
Signal voltage HIGH	$V_S - 2.9$ V											
	V_S											
Signal voltage LOW ⁶⁾	Approx. 0 V											
	≤ 2.9 V											
Output current I_A max.	≤ 100 mA											
Response time⁷⁾	≤ 625 μ s											
Switching frequency max.⁸⁾	800/s											
Connection types	Connection cable, 2 m											
	Cable, 120 mm, with plug M 12, 4-pin											
	Plug M 12, 4-pin											
	Plug M 8, 4-pin											
VDE protection class⁹⁾												
Enclosure rating	IP 67											
Circuit protection¹⁰⁾	A, B, C											
Ambient temperature T_A¹¹⁾	Operation - 40... + 60 °C											
	Storage - 40... + 75 °C											
Weight												
with connection cable 2 m/120 mm	Approx. 80 g											
with equipment plug M 12/M 8, 4-pin	Approx. 20 g											

- 1) Object with 90 % remission (referred to standard white DIN 5033)
- 2) Limit values
- 3) Must be within V_S tolerances
- 4) Without load
- 5) Average service life at room temperature 50,000 h at $T_A = +25$ °C
- 6) At $T_A = +25$ °C and 100 mA output current
- 7) With resistive load
- 8) With light/dark ratio 1:1
- 9) Reference voltage 50 V
- 10) A = supply connections reverse-polarity protected
B = outputs short-circuit protected
C = interference suppression
- 11) Do not bend below 0 °C

Teach-in function

- **Programming via teach-in button.**
- **Simple programming:**
Position object in the beam and push the button: finished;
LED confirms the teach-in procedure.
- **Teach-in values can be stored.**
- **Two operating modes:**
Default setting: short teach-in time (< 8 s);
for standard applications;
approx. double reserve via switching threshold;
LED lights continuously.
Precise setting: long teach-in time (> 8 s);
for precise applications;
small switching hysteresis;
LED blinks.

Scanning distance

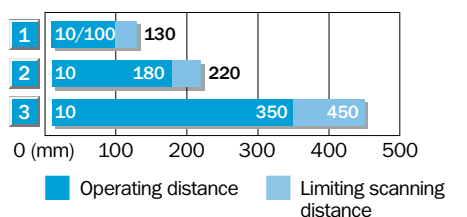

- 1 Scanning distance on black, 6 % remission
- 2 Scanning distance on gray, 18 % remission
- 3 Scanning distance on white, 90 % remission

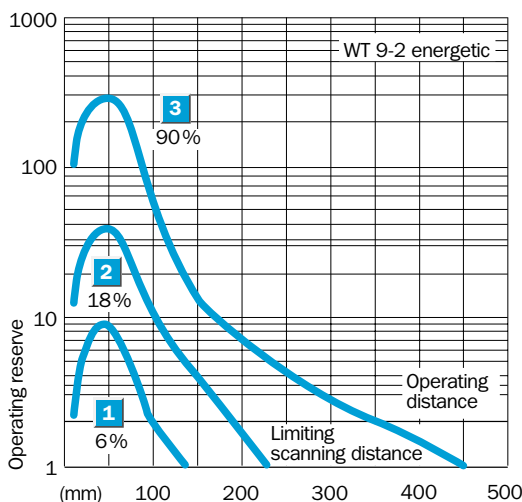

Order information

Type	Part no.
WT 9-2P 151	1 018 297
WT 9-2P 351	1 019 027
WT 9-2P 451	1 018 299
WT 9-2P 651	1 019 273
WT 9-2N 151	1 018 298
WT 9-2N 451	1 018 300

Scanning range
 0...4 m
Photoelectric reflex switches

- Red-light sender LED as alignment aid
- Switching frequency 800/s
- Outputs short-circuit protected
- Teach-in

Dimensional drawing

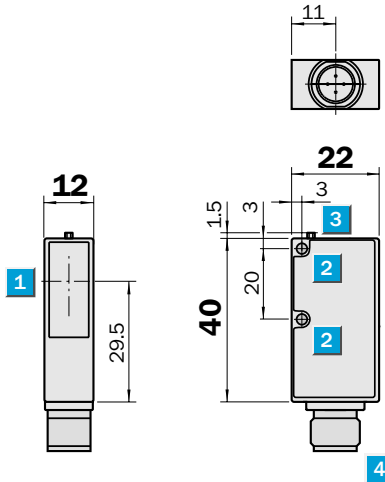

Adjustments possible

WL 9-2P 131	WL 9-2N 131
WL 9-2P 331	WL 9-2N 431
WL 9-2P 431	
WL 9-2P 631	

- 1 Centre of optical axis
- 2 Mounting hole \varnothing 3.2 mm
- 3 LED signal strength indicator
- 4 Plug M 12 or M 8, 4 pin, 2 m connection cable or 120 mm cable with plug M 12, 4-pin
- 5 Sensitivity adjustment with teach-in

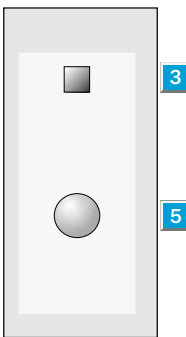

Connection types

WL 9-2P 131	WL 9-2P 331	WL 9-2P 431	WL 9-2P 631
WL 9-2N 131		WL 9-2N 431	

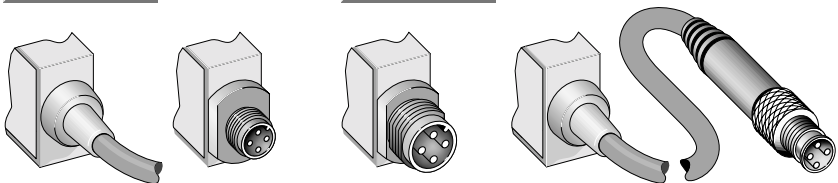

4 x 0.14 mm ²	4-pin, M 8	4-pin, M 12	4-pin, M 12 with 120 mm cable
--------------------------	------------	-------------	-------------------------------

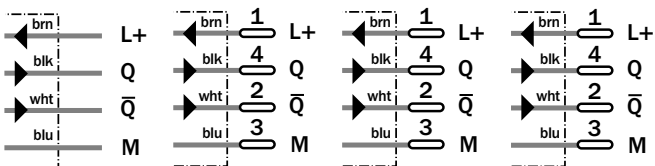

Accessories	page
Cable receptacles	496
Mounting brackets	510
Reflectors	520
Slit diaphragm card, 4 033 253	-

Technical data		WL 9-2	-P131	-P331	-P431	-P631	-N131	-N431				
Scanning range, max. typical/on refl.	4 m/PL 80 A											
Supply voltage V_S ¹⁾	10...30 V											
Ripple ²⁾	$\leq 5 V_{SS}$											
Current consumption ³⁾	≤ 30 mA											
Light source	LED, visible red light ⁴⁾											
Angle of dispersion	2.5°											
Light spot size	120 x 120 mm at 3 m											
Switching outputs Q and \bar{Q}	PNP											
	NPN											
Signal voltage HIGH	$V_S - 2.9$ V											
	V_S											
Signal voltage LOW ⁵⁾	Approx. 0 V											
	≤ 2.9 V											
Output current I_A max.	≤ 100 mA											
Response time ⁶⁾	≤ 625 μ s											
Max. switching frequency ⁷⁾	800/s											
Connection types	Connection cable, 2 m											
	Cable, 120 mm, with plug M 12, 4-pin											
	Plug M 12, 4-pin											
	Plug M 8, 4-pin											
VDE protection class ⁸⁾												
Enclosure rating	IP 67											
Circuit protection ⁹⁾	A, B, C											
Ambient temperature T_A ¹⁰⁾	Operation - 40...+ 60 °C											
	Storage - 40...+ 75 °C											
Weight												
with connection cable 2 m/120 mm	Approx. 80 g											
with equipment plug M 12/M 8, 4-pin	Approx. 20 g											

- 1) Limit values
- 2) Must be within V_S tolerances
- 3) Without load
- 4) Average service life at room temperature 100,000 h at $T_A = + 25$ °C
- 5) At $T_A = + 25$ °C and 100 mA output current
- 6) With resistive load
- 7) With light/dark ratio 1:1
- 8) Reference voltage 50 V
- 9) A = supply connections reverse-polarity protected
B = outputs short-circuit protected
C = interference suppression
- 10) Do not bent below 0 °C

Teach-in function

- **Programming via teach-in button.**
- **Simple programming:**
Position object in the beam and push the button: finished;
LED confirms the teach-in procedure.
- **Teach-in values can be stored.**
- **Two operating modes:**
Default setting: short teach-in time (< 8 s);
for standard applications;
approx. double reserve via switching threshold;
LED lights continuously.
Precise setting: long teach-in time (> 8 s);
for precise applications;
small switching hysteresis;
LED blinks.

Scanning range

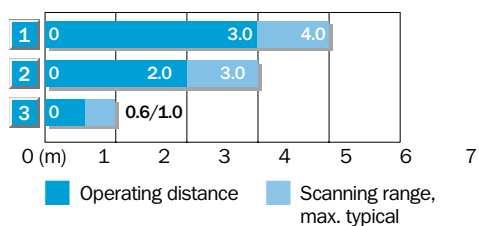

Reflector type	Operating range
1 PL 80 A	0...3.0 m
2 PL 50 A	0...2.0 m
3 Reflective tape Diamond Grade*	0...0.6 m

* 100 x 100 mm²

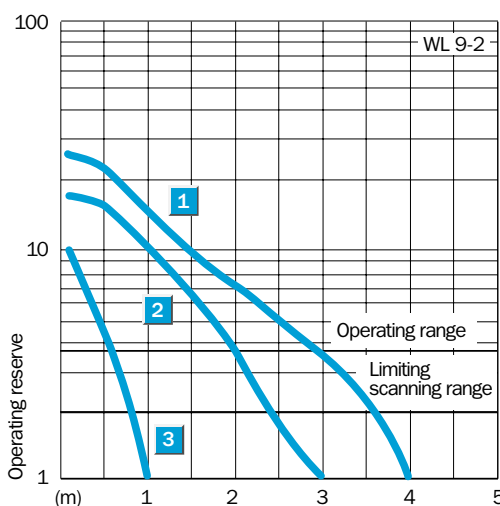

Order information

Type	Part no.
WL 9-2P 131	1 018 285
WL 9-2P 331	1 019 025
WL 9-2P 431	1 018 287
WL 9-2P 631	1 019 269
WL 9-2N 131	1 018 286
WL 9-2N 431	1 018 288

Photoelectric switches without teach-in and photoelectric switches with focused optics as well as through-beam photoelectric switches on request.